

RECOMMENDED PROCEDURE FOR  
VENTURE MFG. CO.  
 COUPLER AND JACK INSTALLATION

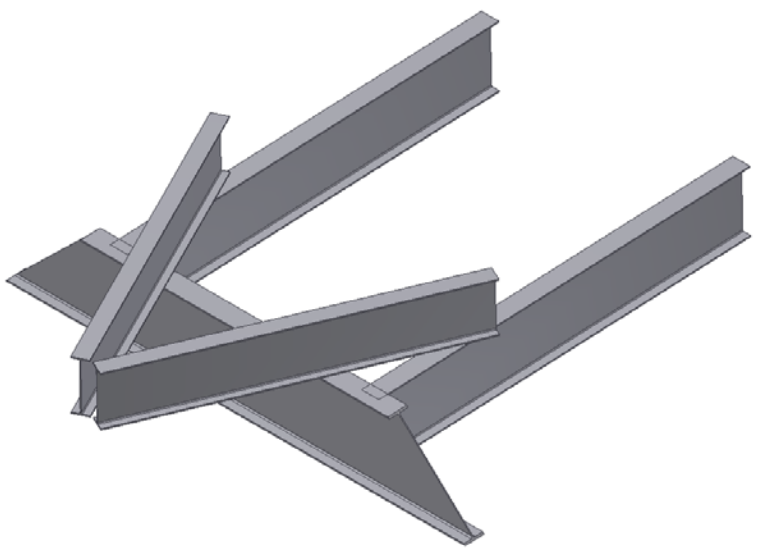

STEP NO. 1  
 PLACE DRAWBARS ONTO MAIN  
 FRAME—DO NOT WELD IN PLACE

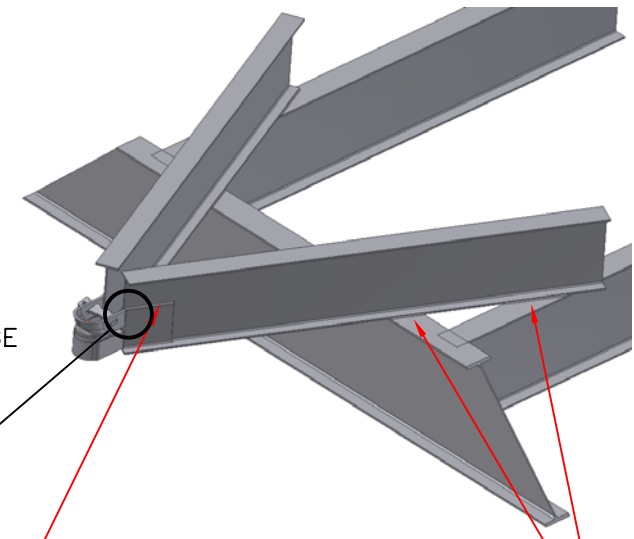

STEP NO. 2  
 WELD COUPLER FROM EDGE  
 OF FLANGE COMPLETELY  
 AROUND MOUNTING LEGS

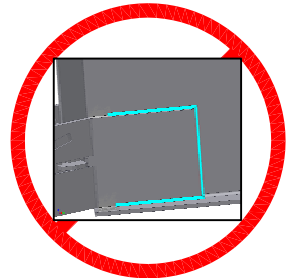

NO

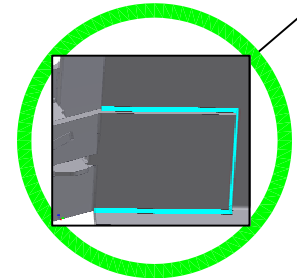

OK

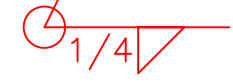

STEP NO. 3  
 POSITION A-FRAME  
 WELD DRAWBARS OR  
 DETACH. PLATES  
 IN PLACE

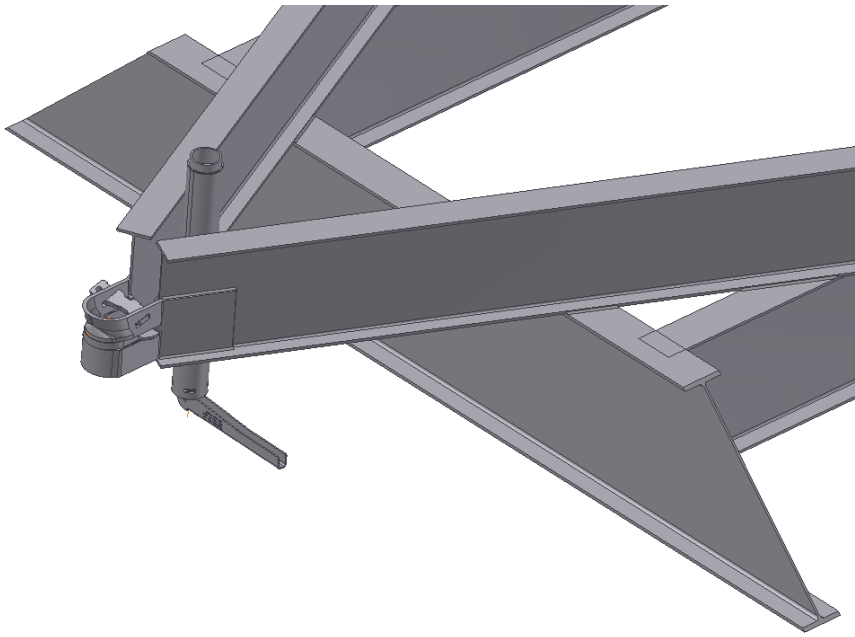

STEP NO. 4  
 DROP JACK INSIDE—RESTING ON  
 THE INNER FLANGES OF DRAWBARS  
 WELD ON INSIDE—ALONG EACH EDGE  
 (SEE WELD VIEW)

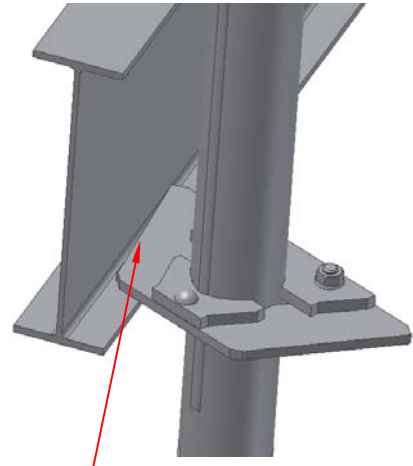

1/4"  WELD HERE  
 ALONG EACH SIDE

JACK WELD VIEW  
 (ENLARGED)

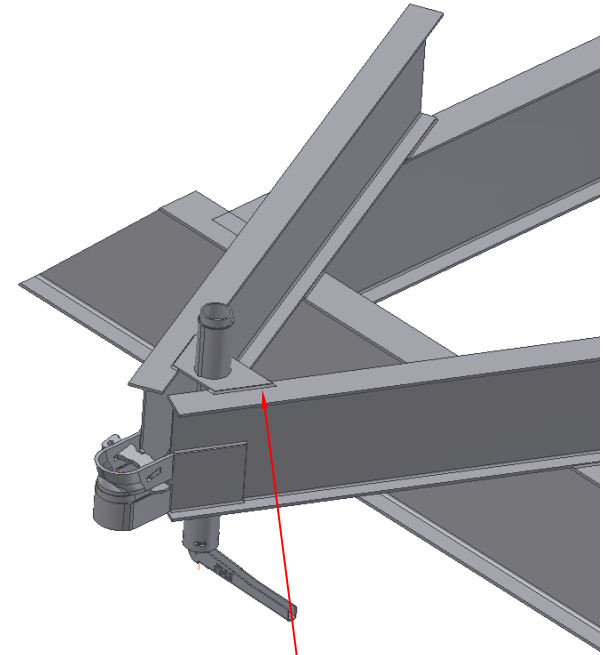

STEP NO. 5  
 DROP LOWER SUPPORT PLATE  
 OVER JACK STEM WELD  
 AROUND EDGES

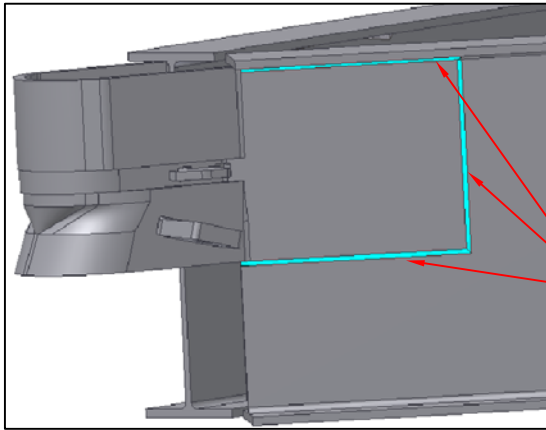

TOP MOUNT

↑  
UP

WELD

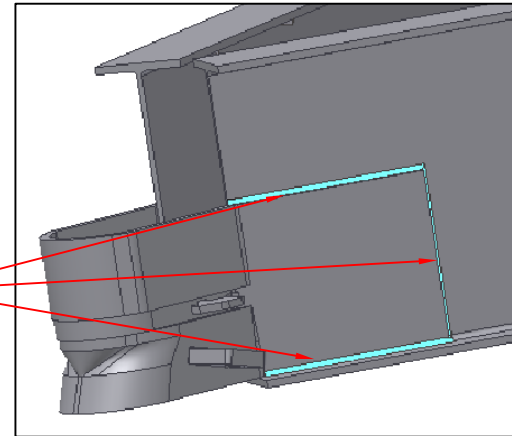

BOTTOM MOUNT

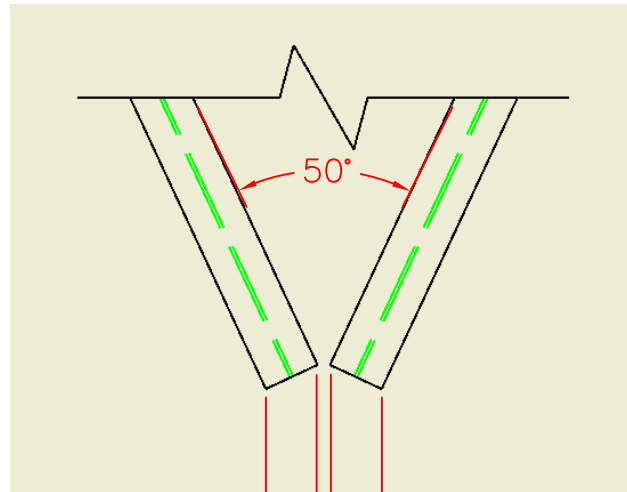

50°

3/16" - 10" BEAM  
1/2" - 8" BEAM

2 3/4" OUTSIDE  
DIM.

NOTE: IF PROBLEM IS ENCOUNTERED, NOTE SERIAL NUMBER OF FRAME OR HOME, MODEL (SINGLE OR DOUBLE WIDE), SIZE (EXP: 14' X 80' SINGLE, 5 AXES, ECT.) AND ANY AVAILABLE WEIGHT DATA (TONGUE, GVW) CALCULATED OR ACTUAL.

UNDER FLANGE MOUNT

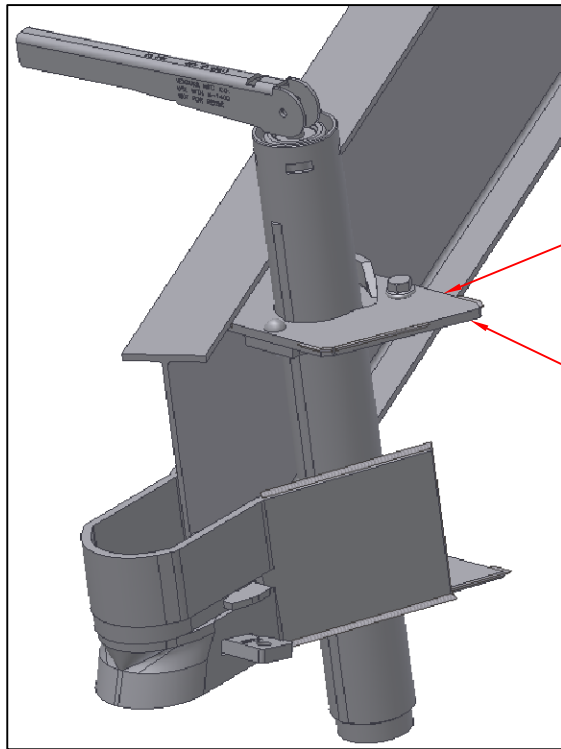

UP ↑

PUSH

T.F.P.

TOP FLANGE MOUNT

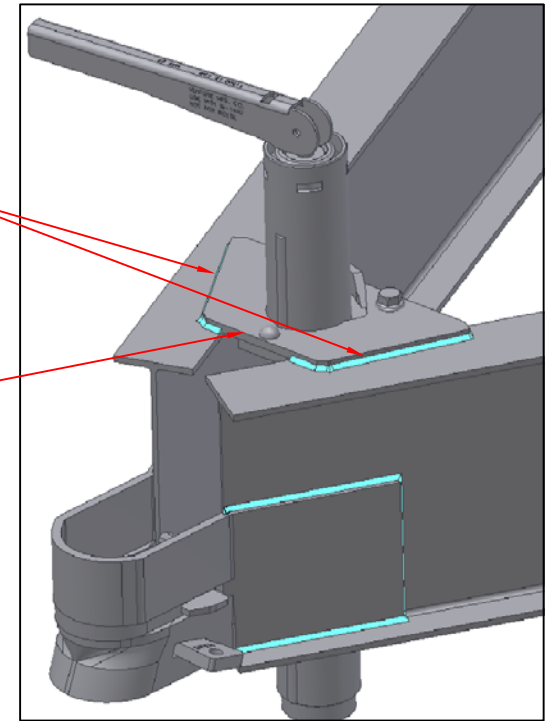

UP ↑

WELD

T.F.P.

WELD HERE  
1/4  
ALONG EACH SIDE

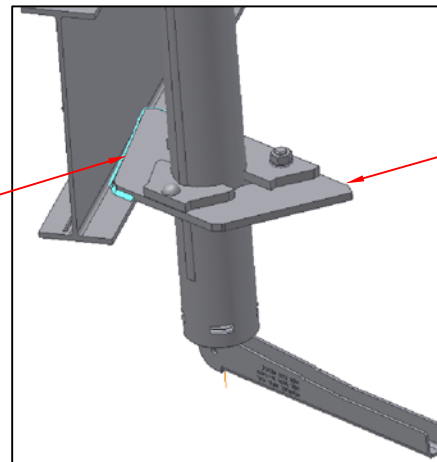

T.F.P.

UP ↓

JACK WELD VIEW

NOTE: IF PROBLEM IS ENCOUNTERED, NOTE SERIAL NUMBER OF FRAME OR HOME, MODEL (SINGLE OR DOUBLE WIDE), SIZE (EXP: 14' X 80' SINGLE, 5 AXES, ECT.) AND ANY AVAILABLE WEIGHT DATA (TONGUE, GVW) CALCULATED OR ACTUAL.

WELD  
TYP.

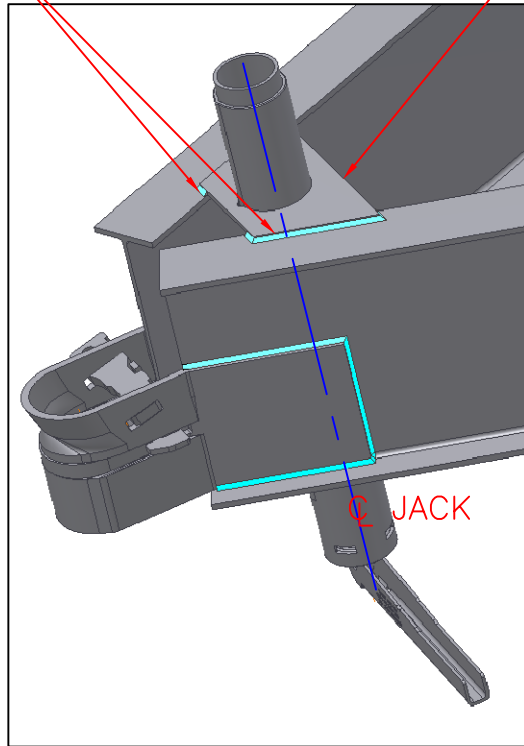

NORMAL WELD INSTALLATION  
OF 1002 LFP ON 8"-10"  
JUNIOR I-BEAM  
FRAME INVERTED - PLATE  
RESTING ON DRAWBAR FLANGES

WELD ON  
UNDERSIDE IF  
INTERFERENCE  
WITH JACK  
TUBE

WELD  
TYP.

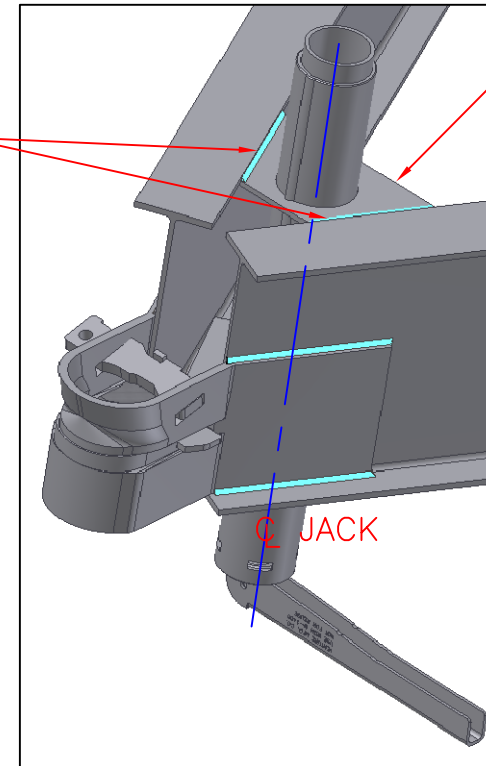

POSITION 1002 L.P.F. UNDER DRAWBAR  
FLANGES WHEN INSTALLED ON  
12" I-BEAM - OTHERWISE PLATE WILL  
NOT SUPPORT OUTER JACK TUBE  
NOTE: PLATE IS DESIGNED TO ALLOW  
INSTALLATION EITHER INSIDE OR  
OUTSIDE OF FLANGES  
FOR CONVENIENCE

NOTE: IF PROBLEM IS ENCOUNTERED, NOTE SERIAL NUMBER OF FRAME OR HOME, MODEL (SINGLE OR DOUBLE WIDE), SIZE (EXP: 14' X 80' SINGLE, 5 AXES, ECT.) AND ANY AVAILABLE WEIGHT DATA (TONGUE, GVW) CALCULATED OR ACTUAL.