

890-01 ~ RAGBX "STD"
 RIGHT ANGLE GBX
 WT ~ 3.15 lbs.

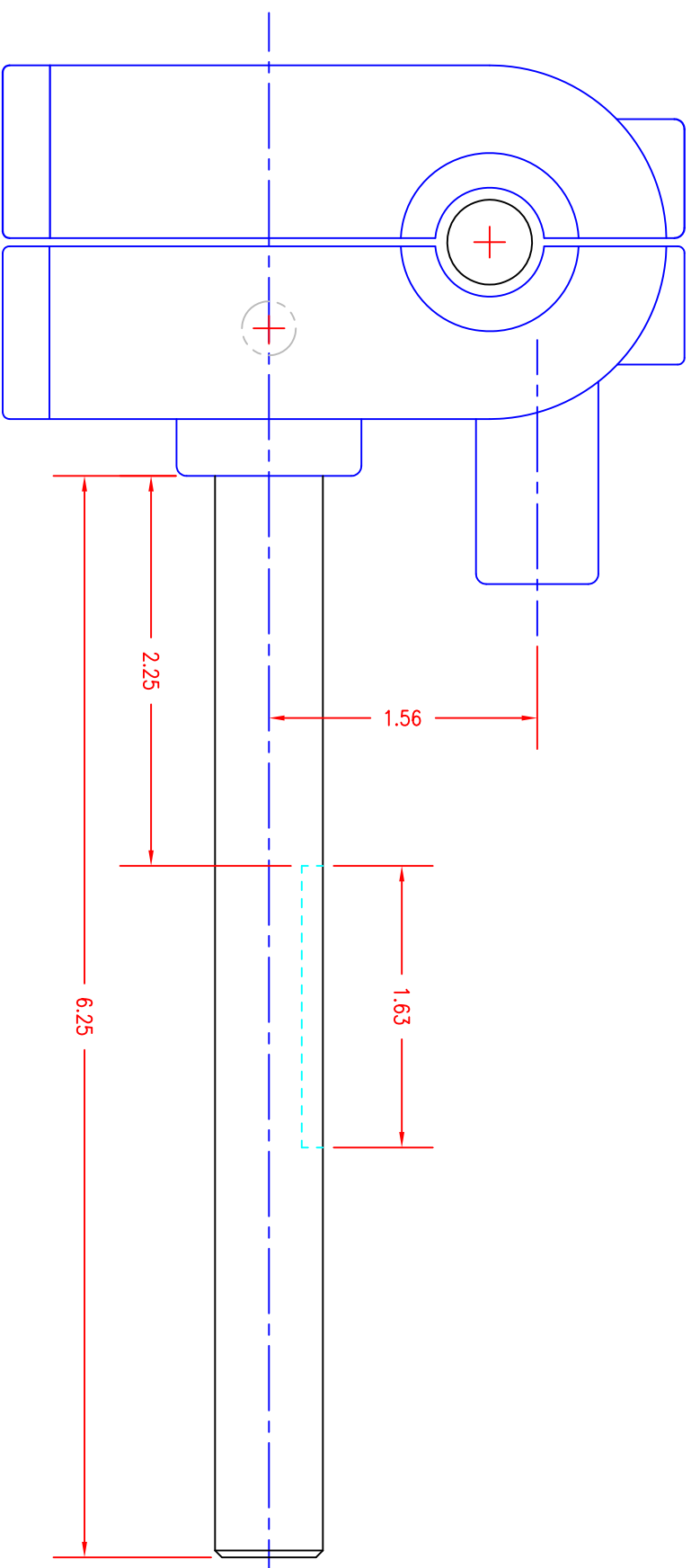

890-01A ~ RAGBX "T"
 RIGHT ANGLE GBX
 WT ~ 2.7 lbs.

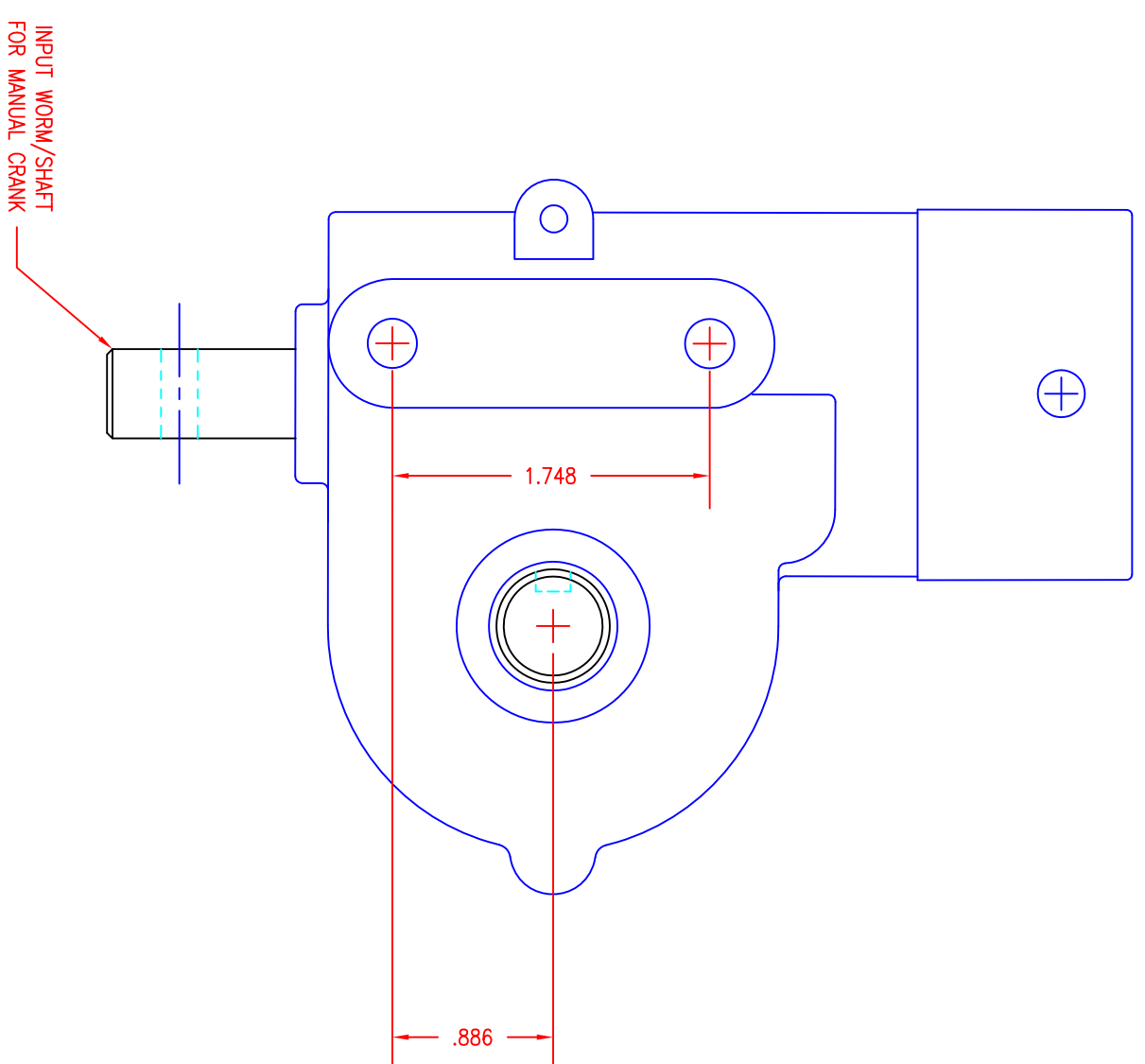
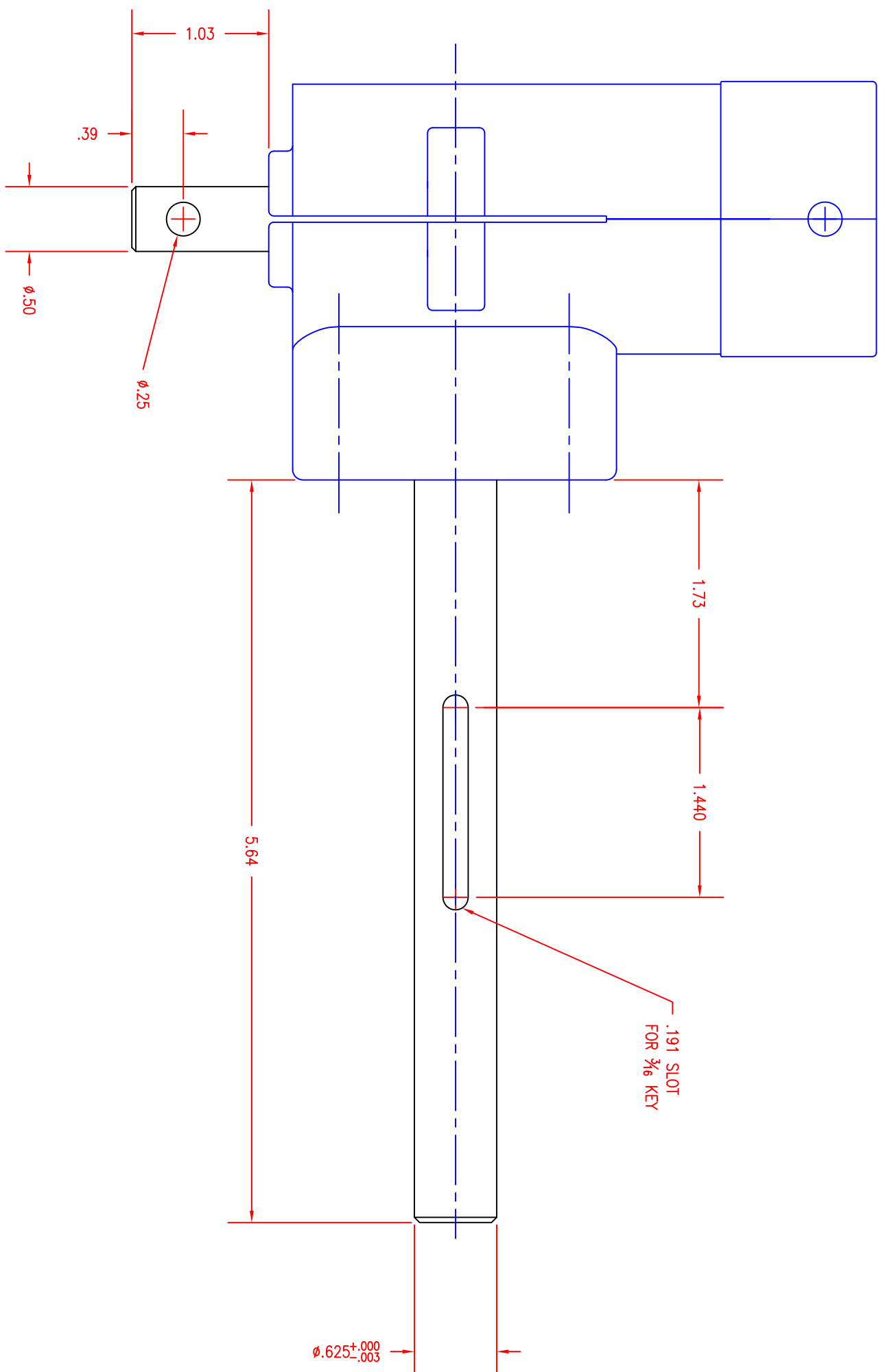
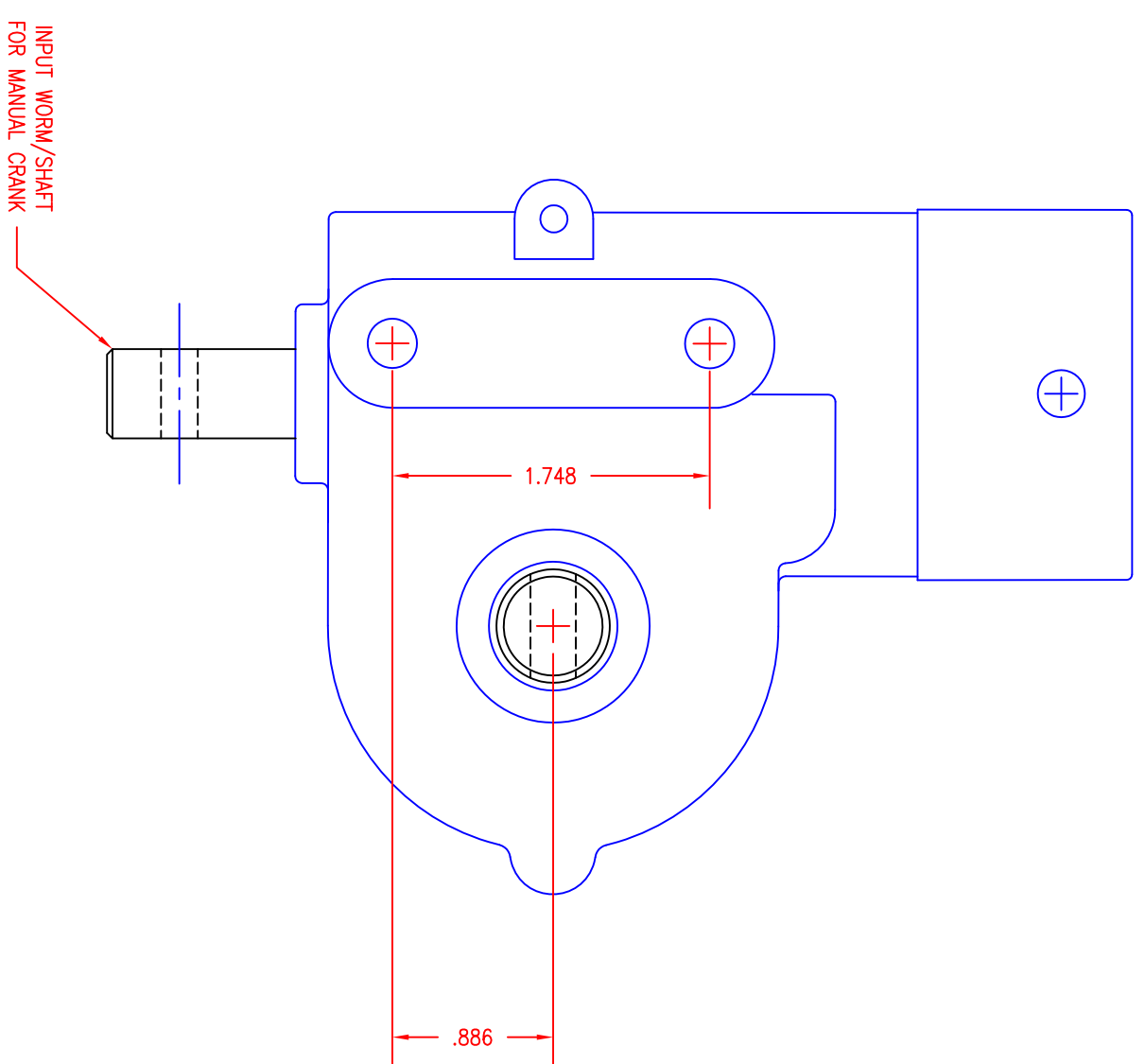
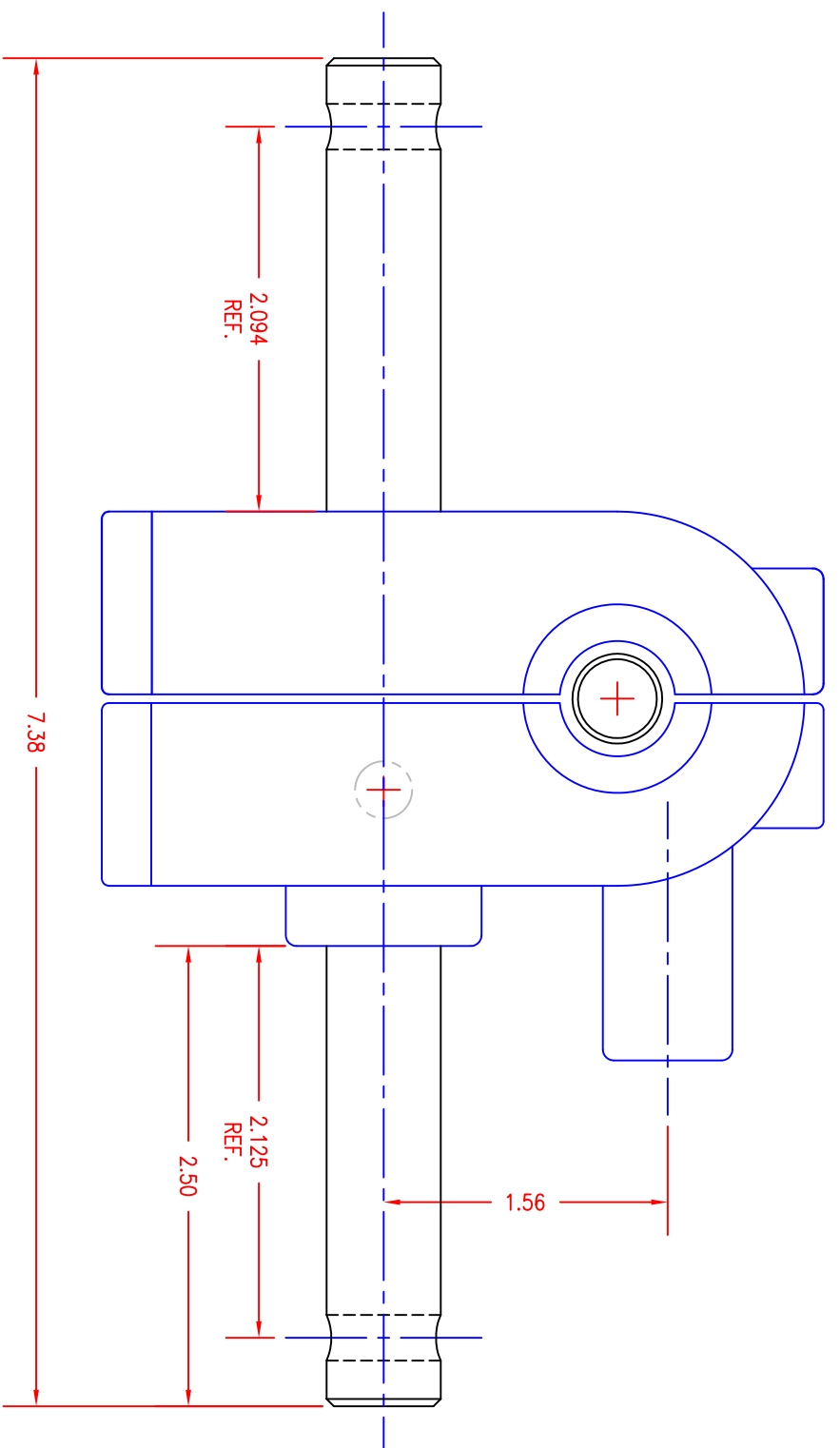
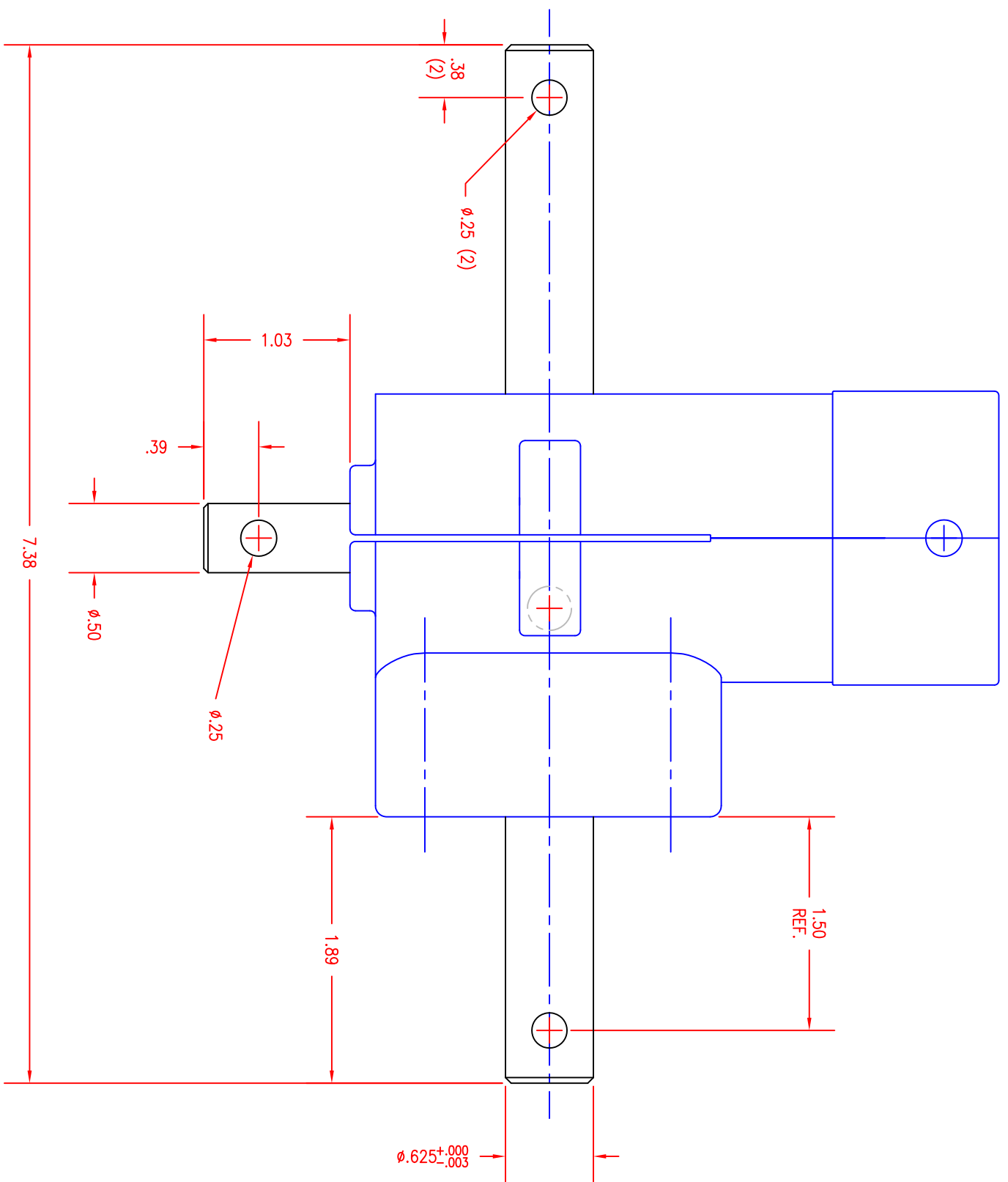

890-01D ~ RAGBOX LOW PRO
 RIGHT ANGLE GBX
 WT ~ 2.6 lbs.

DATE	JAN.2005	VENTURE MFG. CO.	
SCALE	FULL	CA-890-01D	

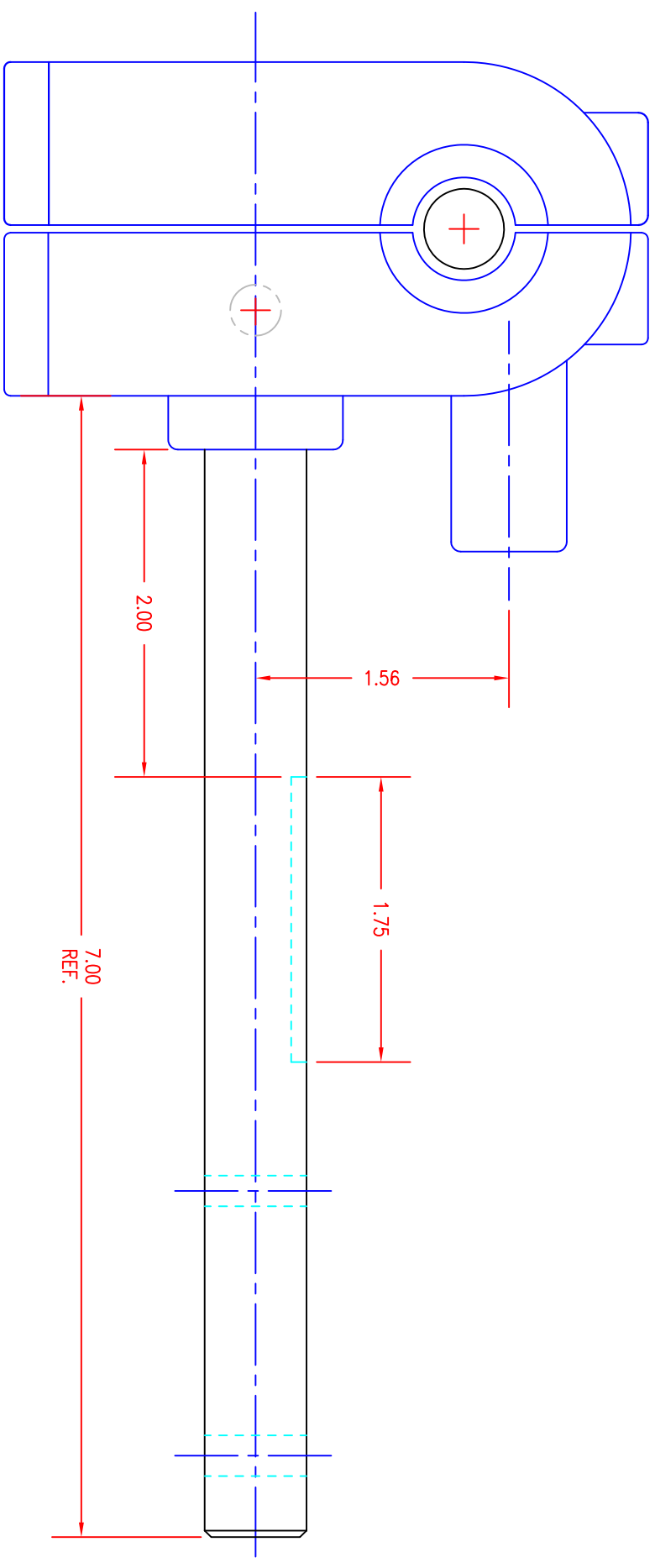
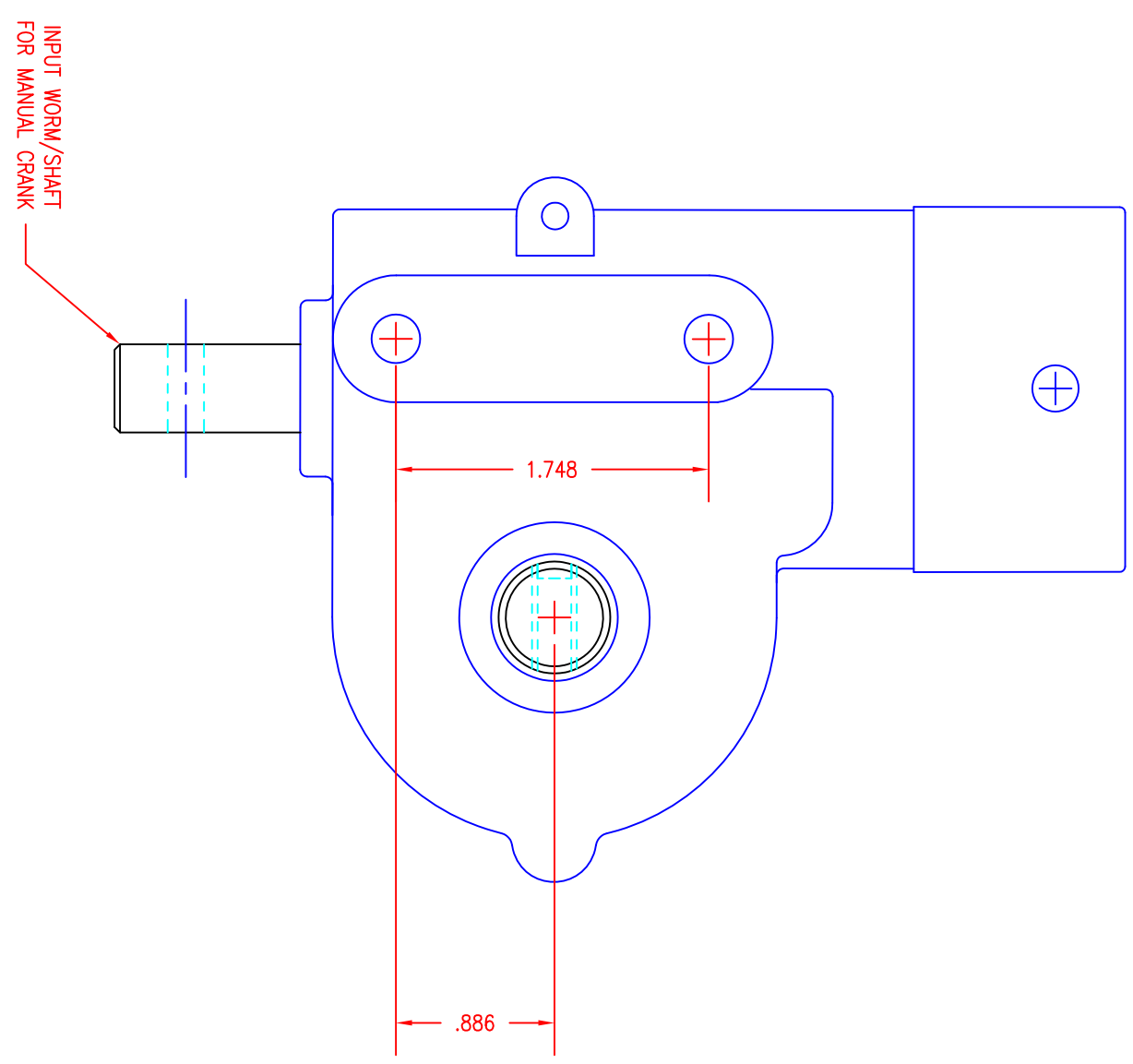
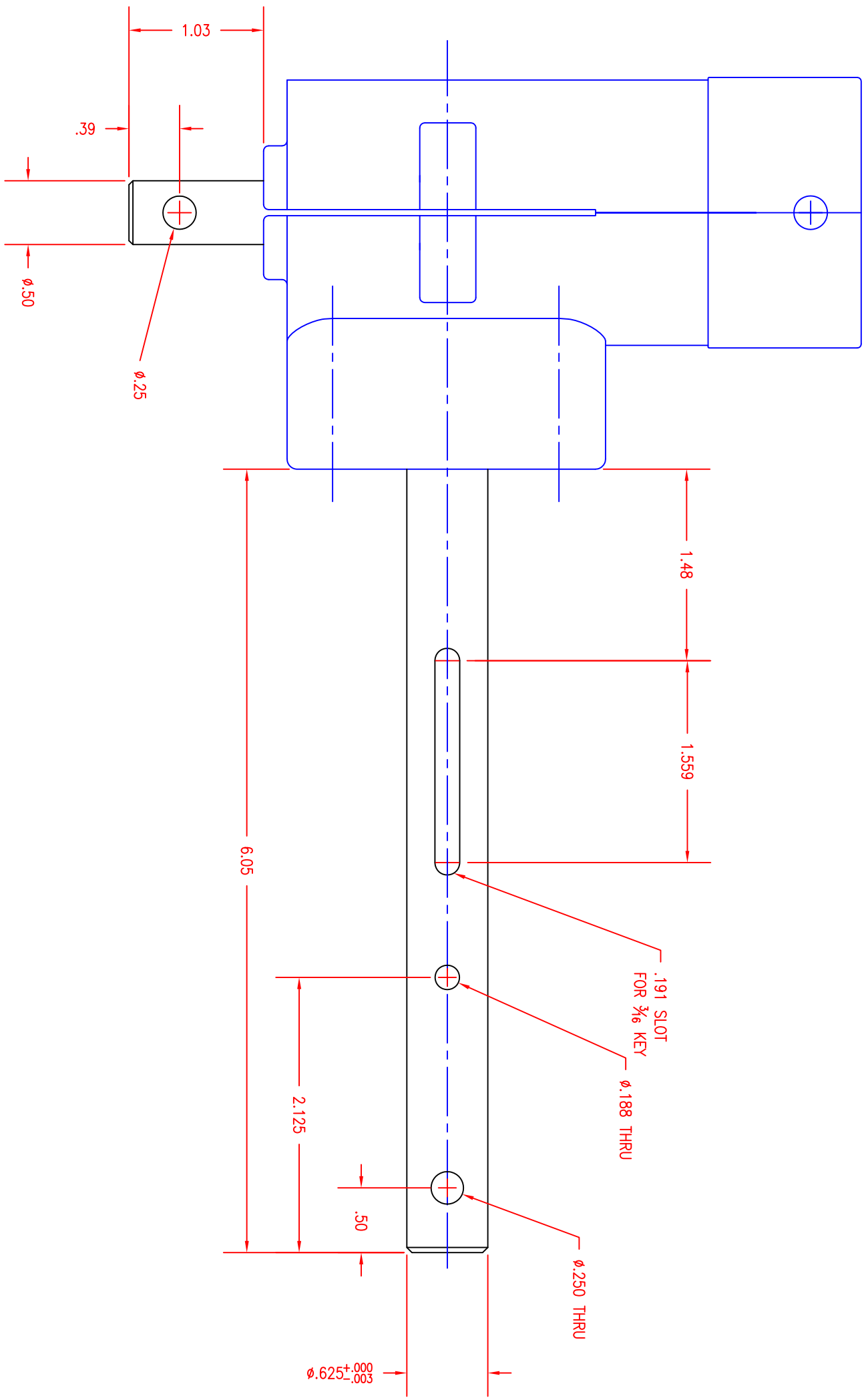

890-01E ~ RAGBX Z
 RIGHT ANGLE GBX
 WT ~ 2.7 lbs.

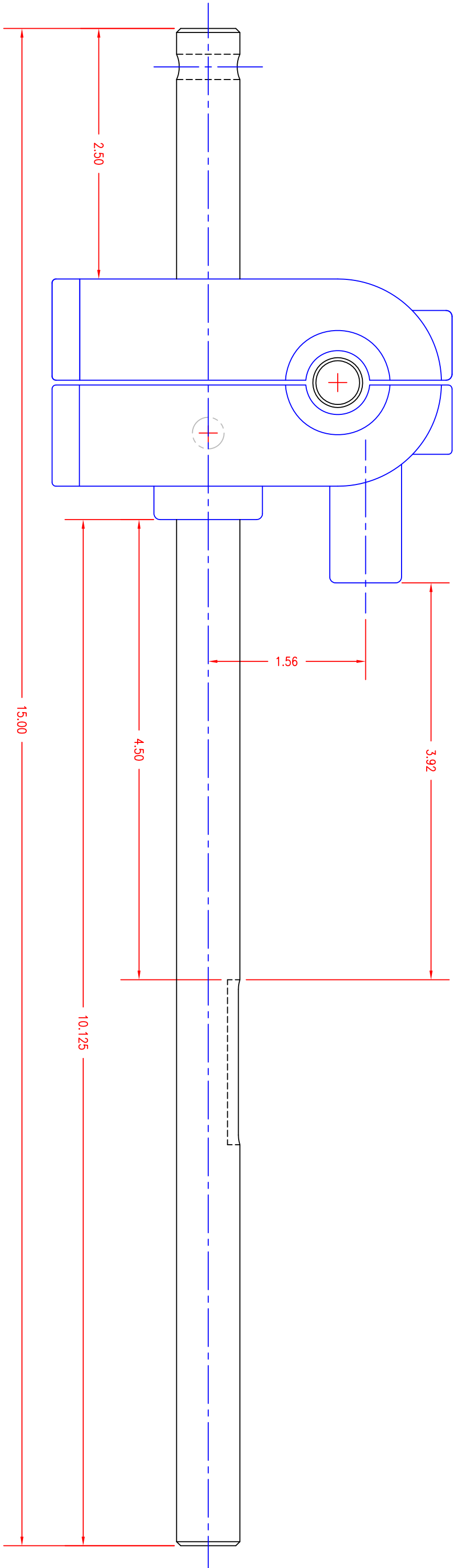
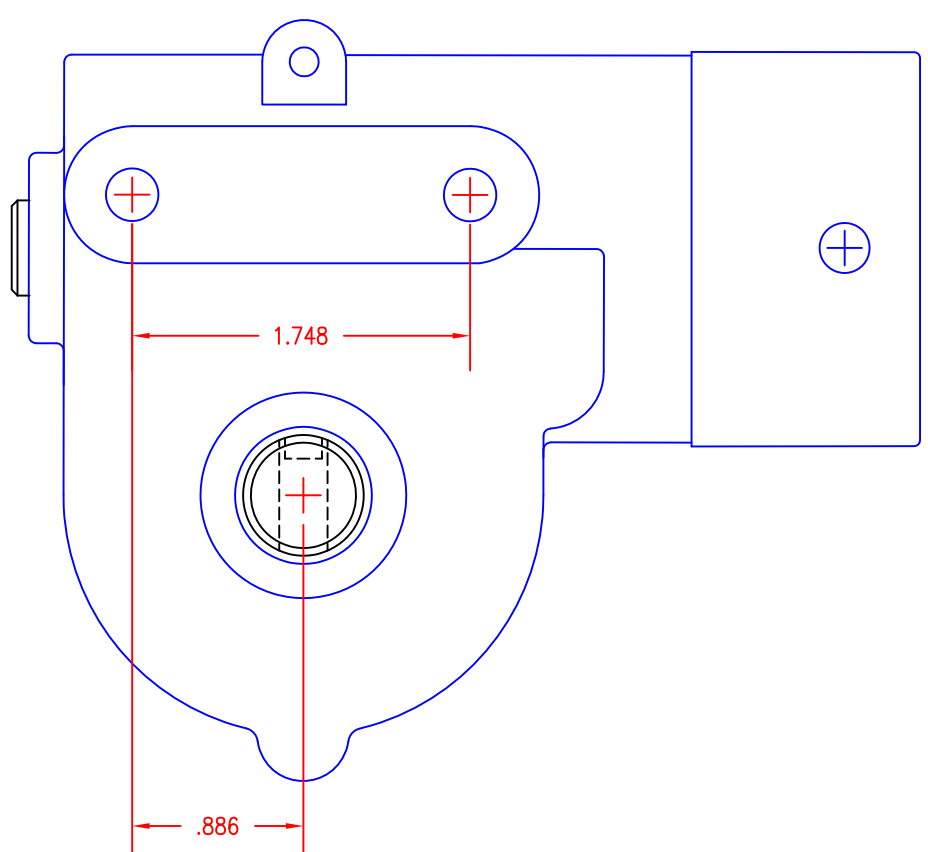
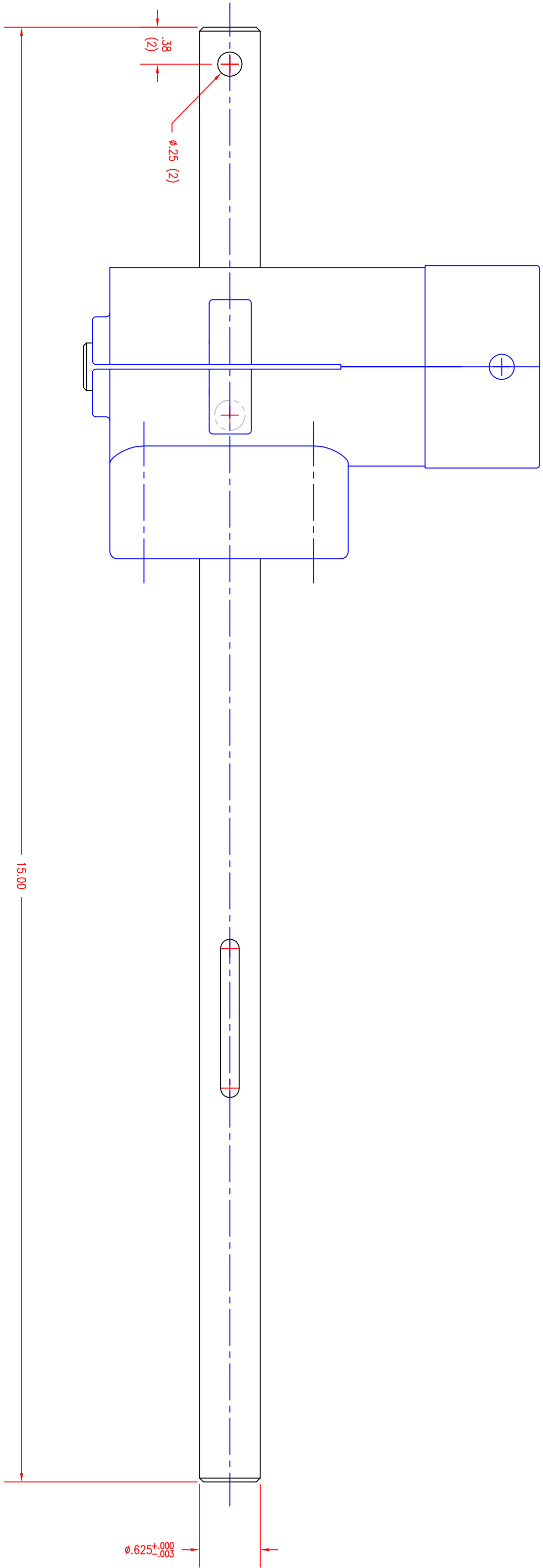

890-02 ~ RAGBOX C
 RIGHT ANGLE GBX
 WT ~ 3.2 lbs.

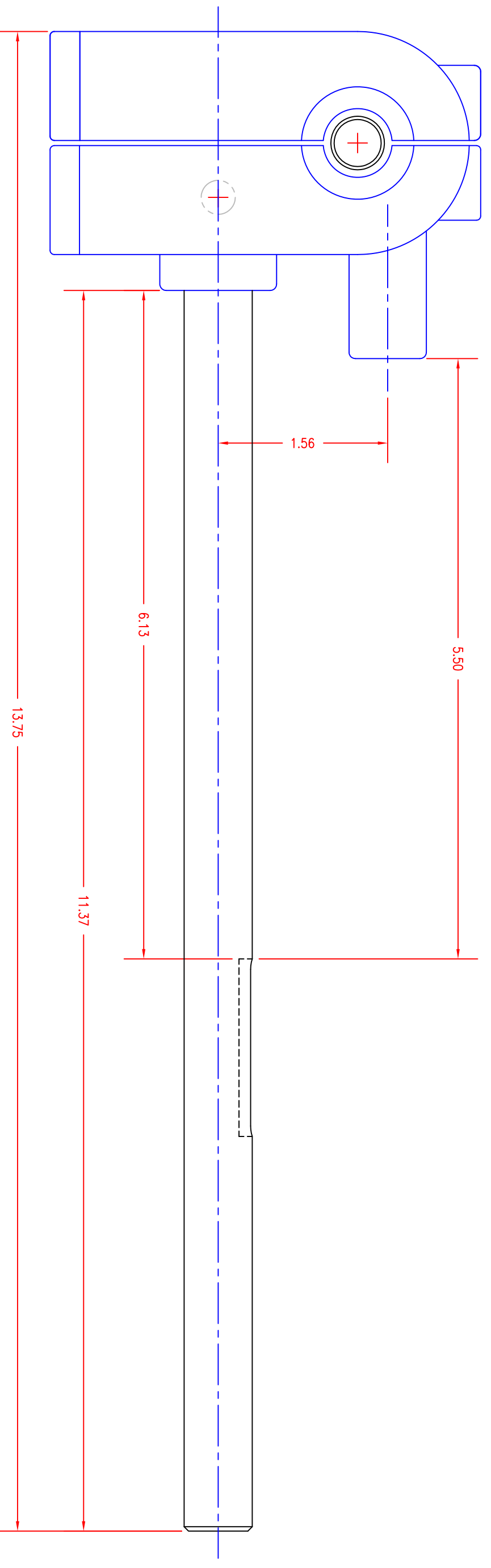
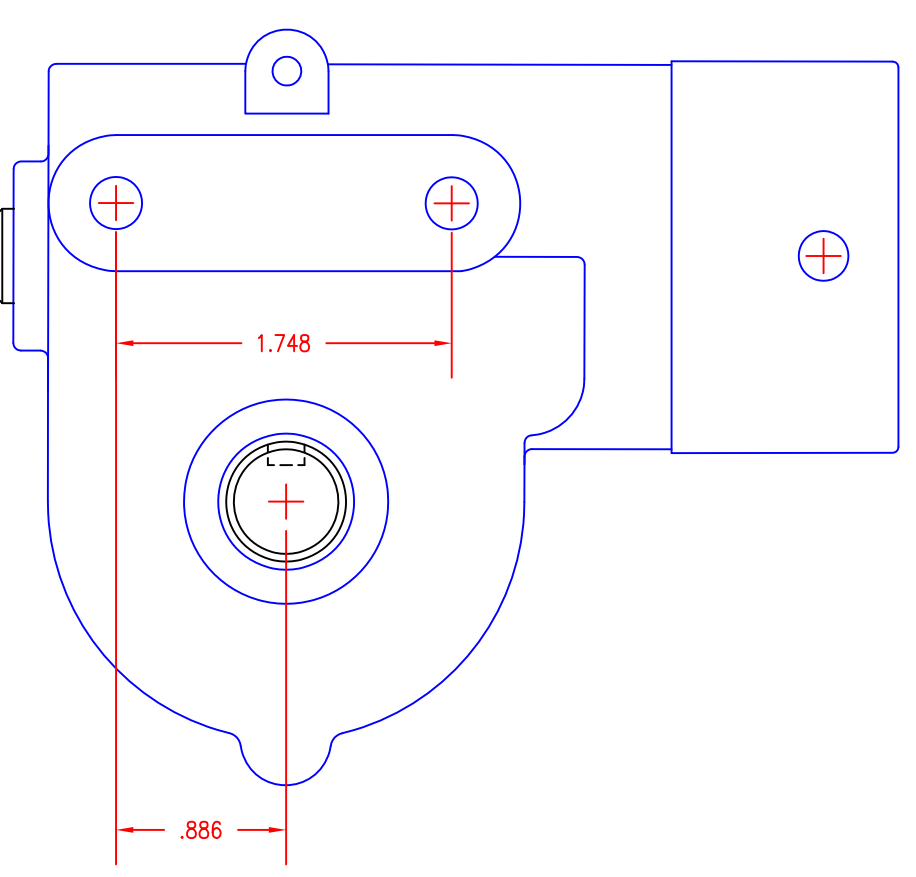
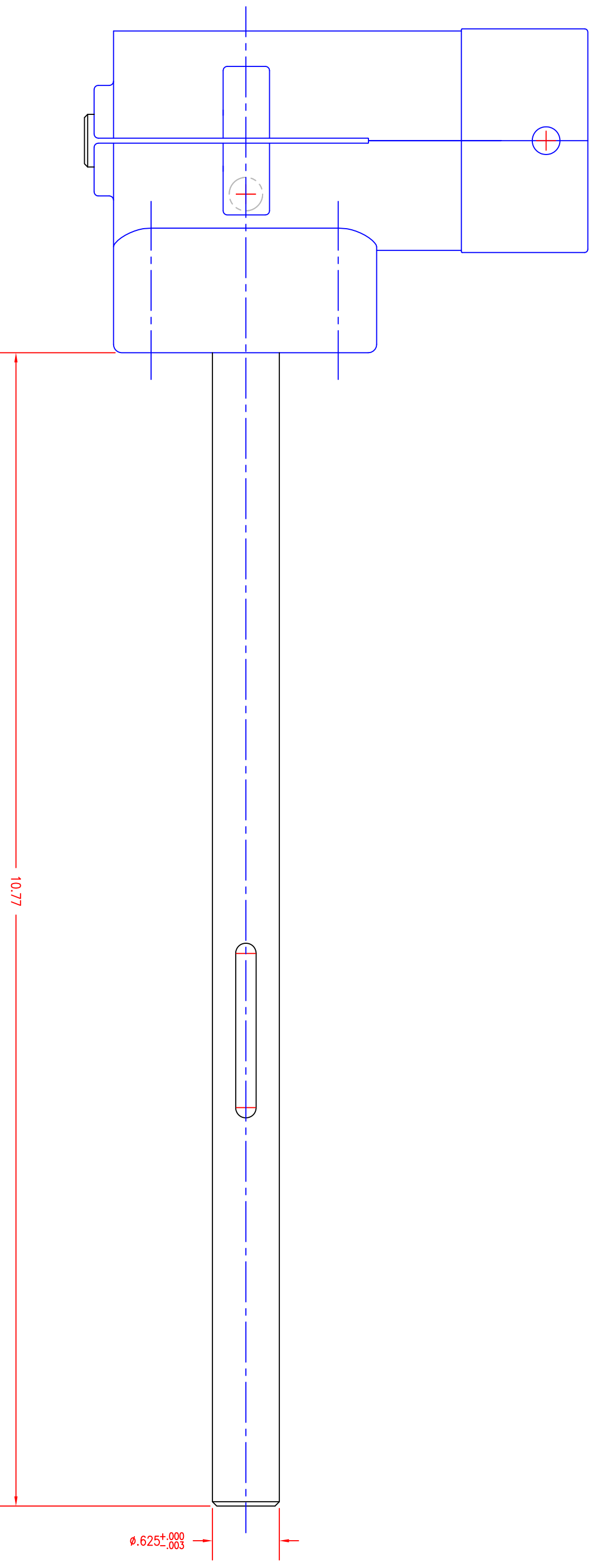

890-02A ~ RAGBOX CS
 RIGHT ANGLE GBX
 WT ~ 3.11 lbs.

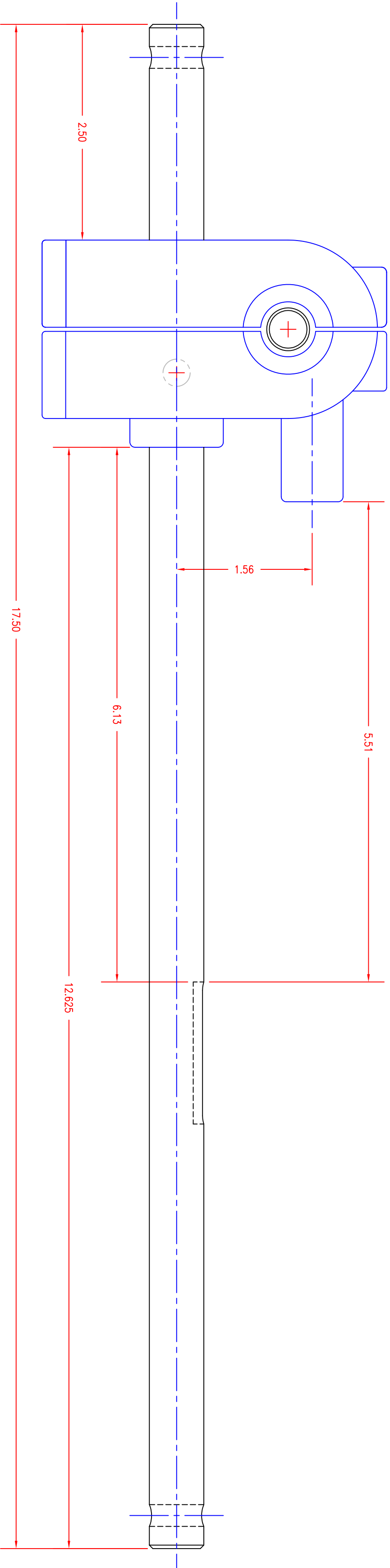
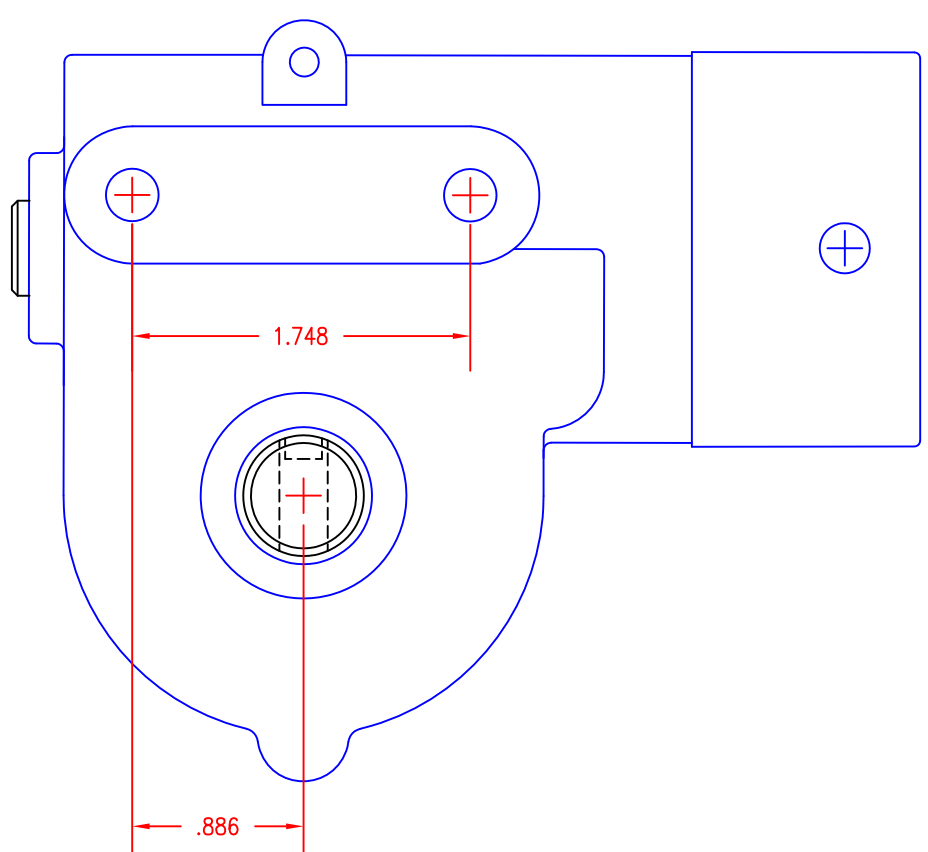
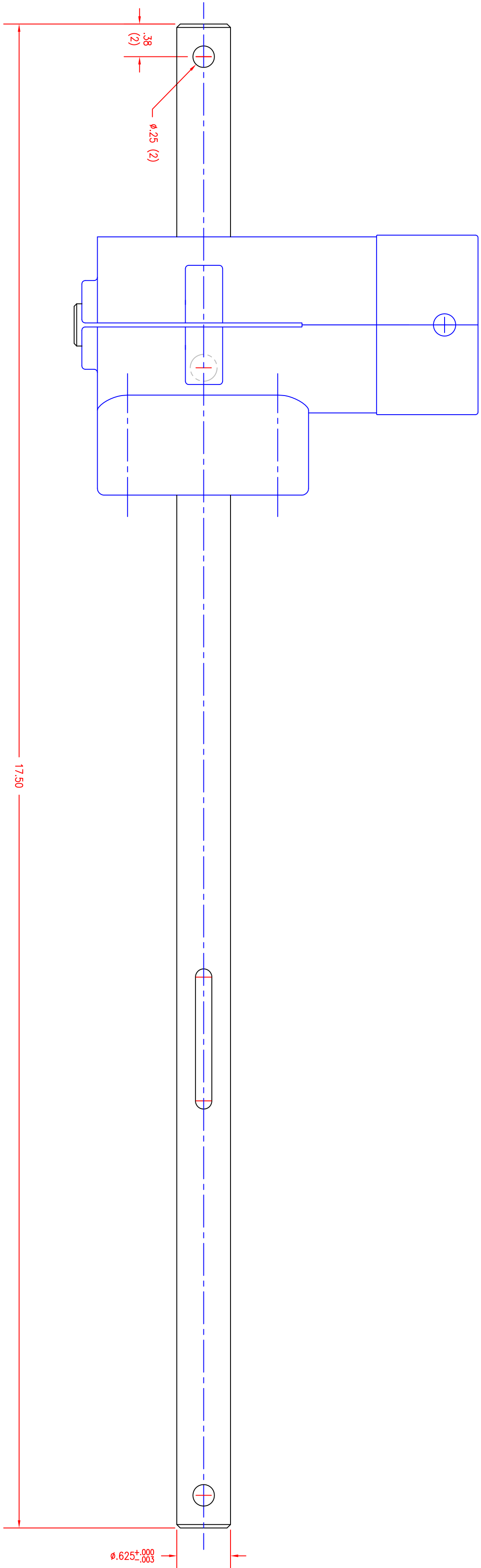

890-02B ~ RAGBOX CD
RIGHT ANGLE GBX
WT ~ 3.4 lbs.

DATE	JAN 2008	VENTURE MFG. CO.		
SCALE	FULL	CA-890-02B		
				A

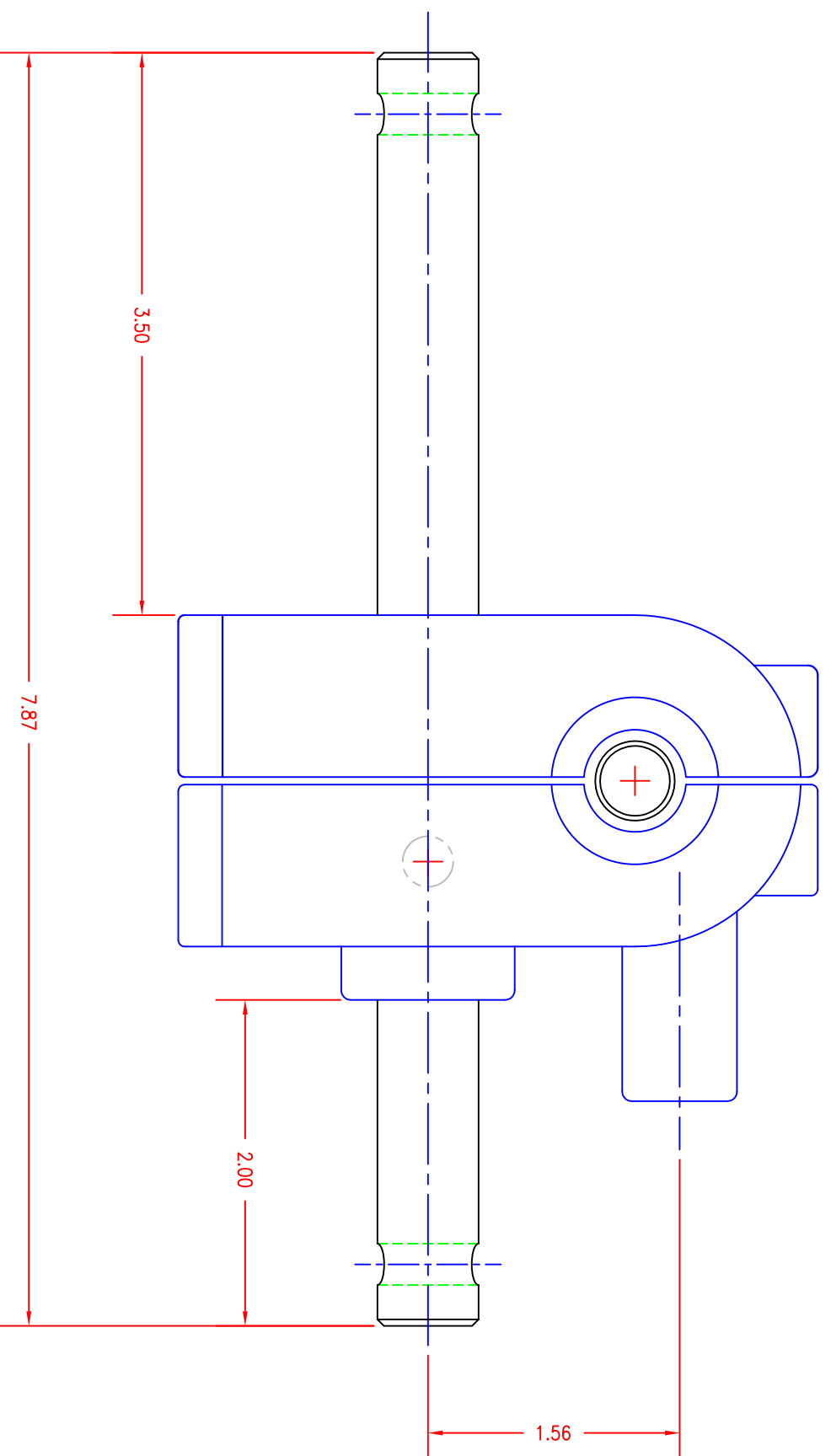
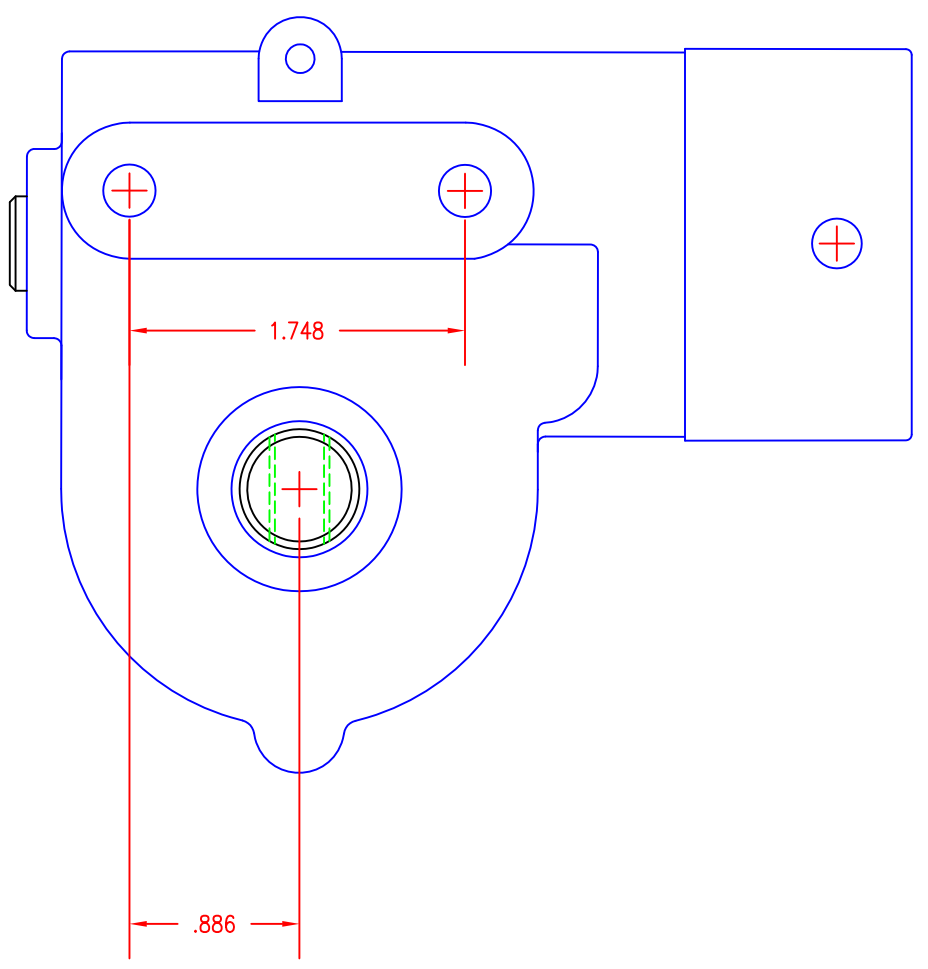
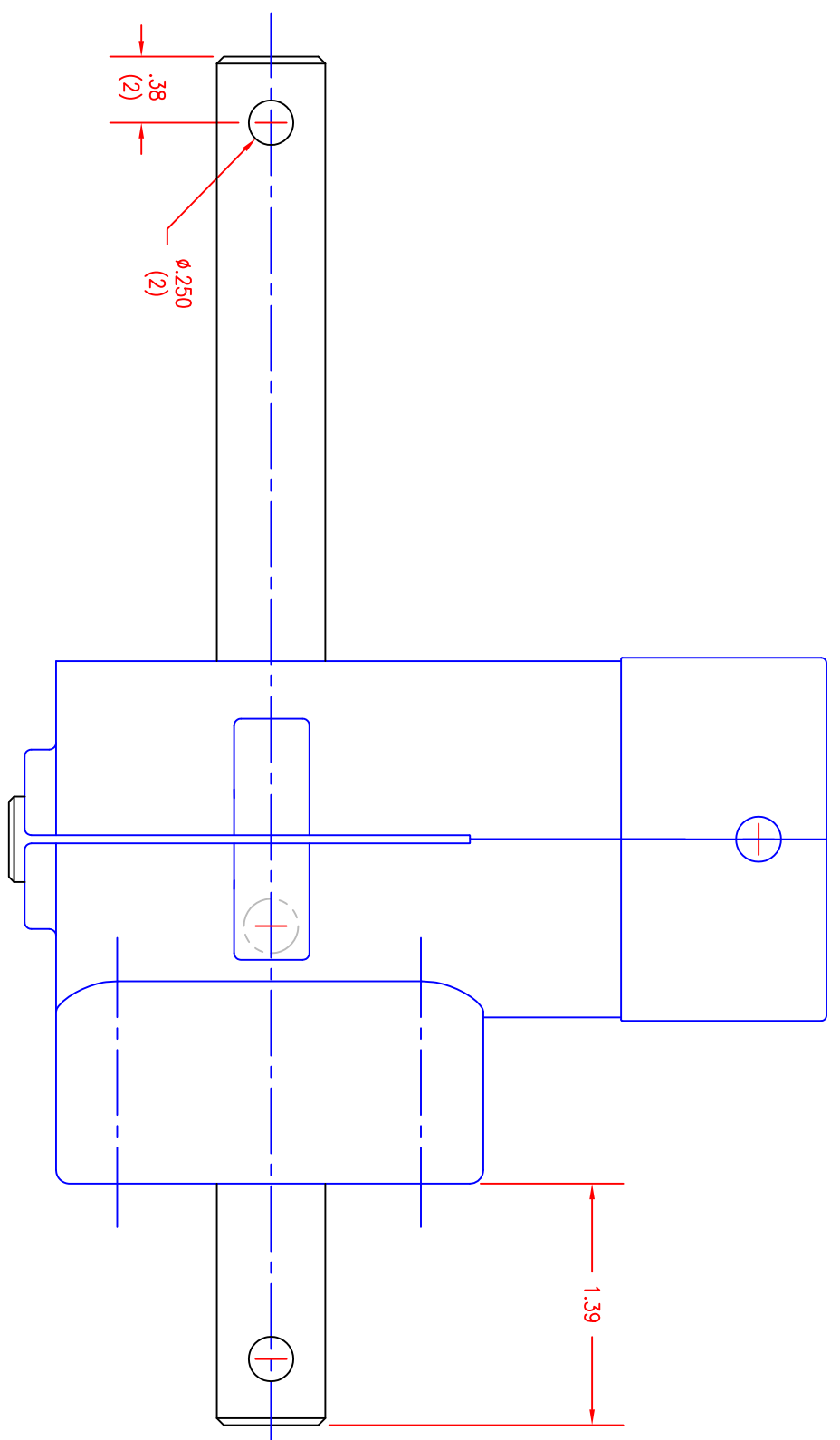

890-02C ~ RAGBOX B
 RIGHT ANGLE GBX
 WT ~ 2.6

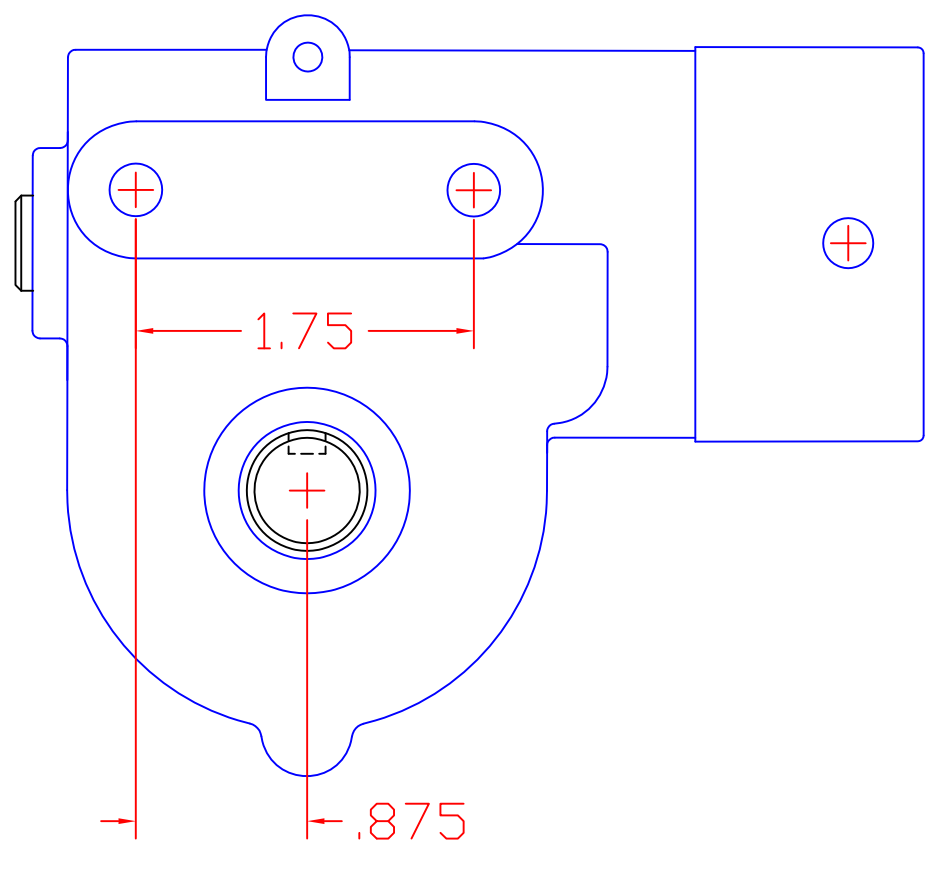
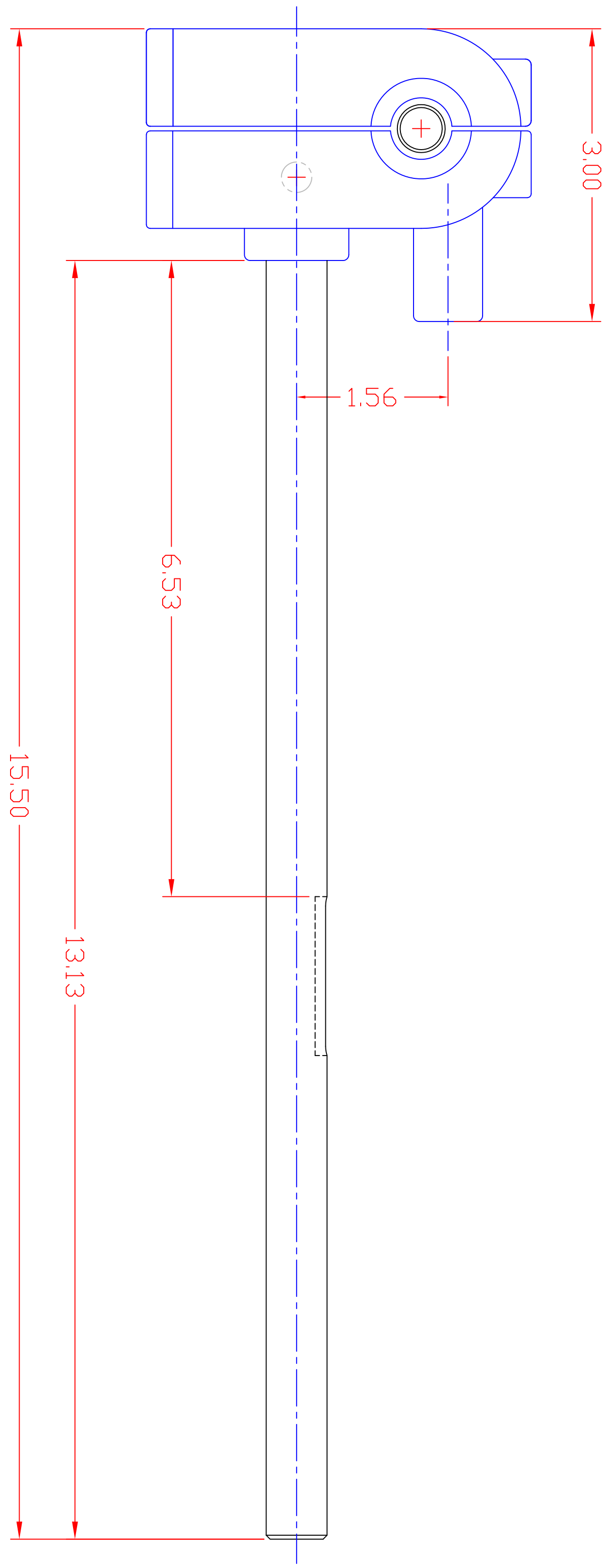
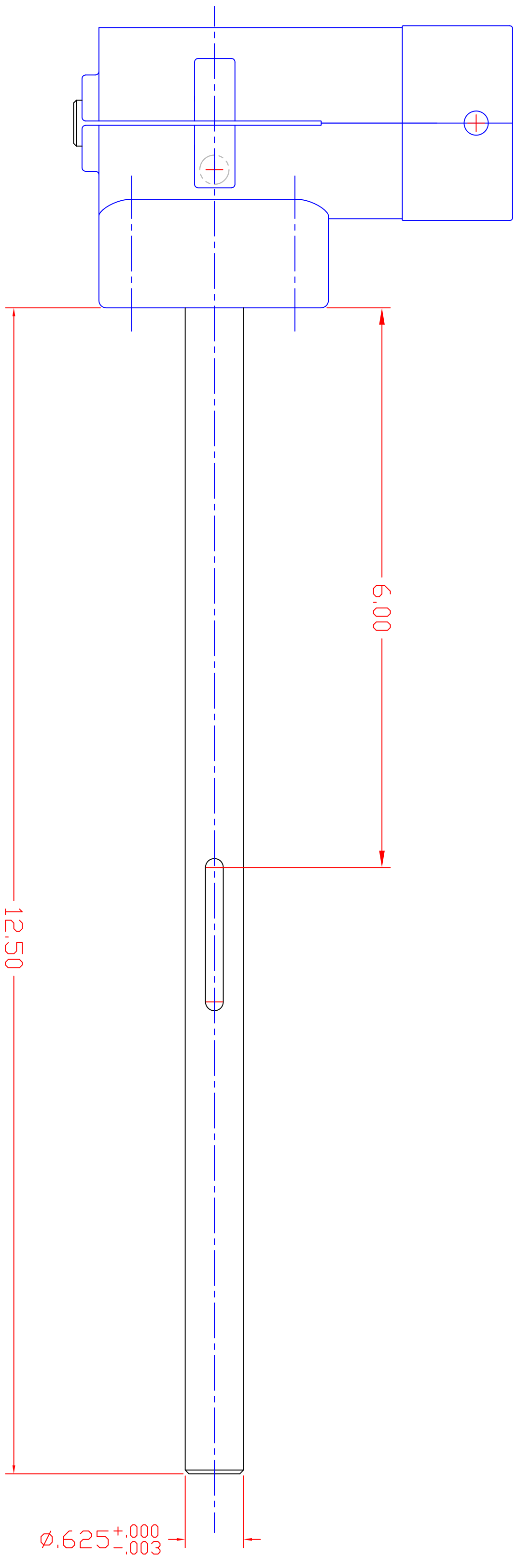

890-02D ~ RAGBOX "FR CC"
RIGHT ANGLE GEARBOX
WT ~ 3.11 lbs.

DATE	JAN 2008	VENTURE MFG. CO.		
SCALE	FULL	CA-890-02D		A

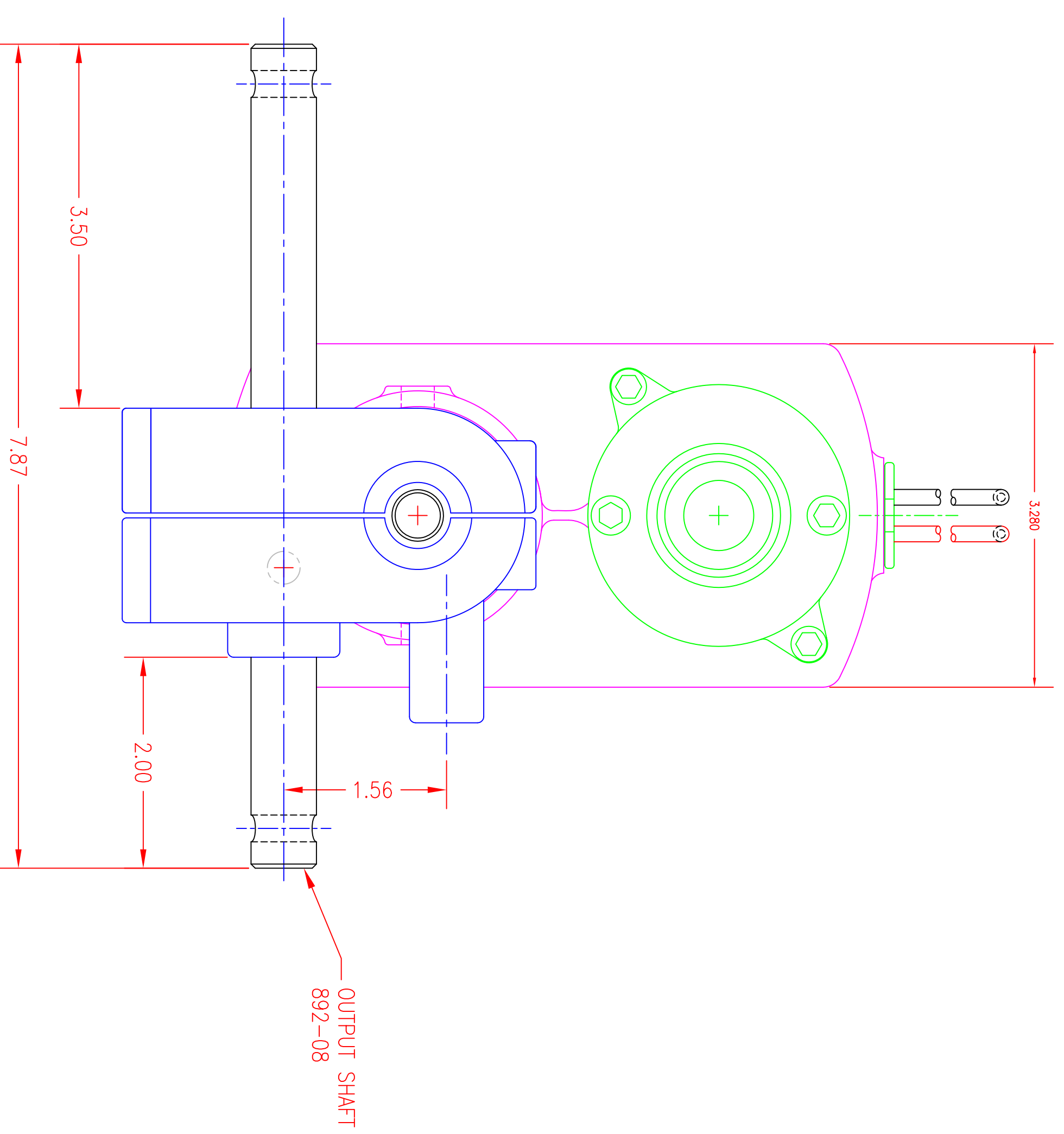
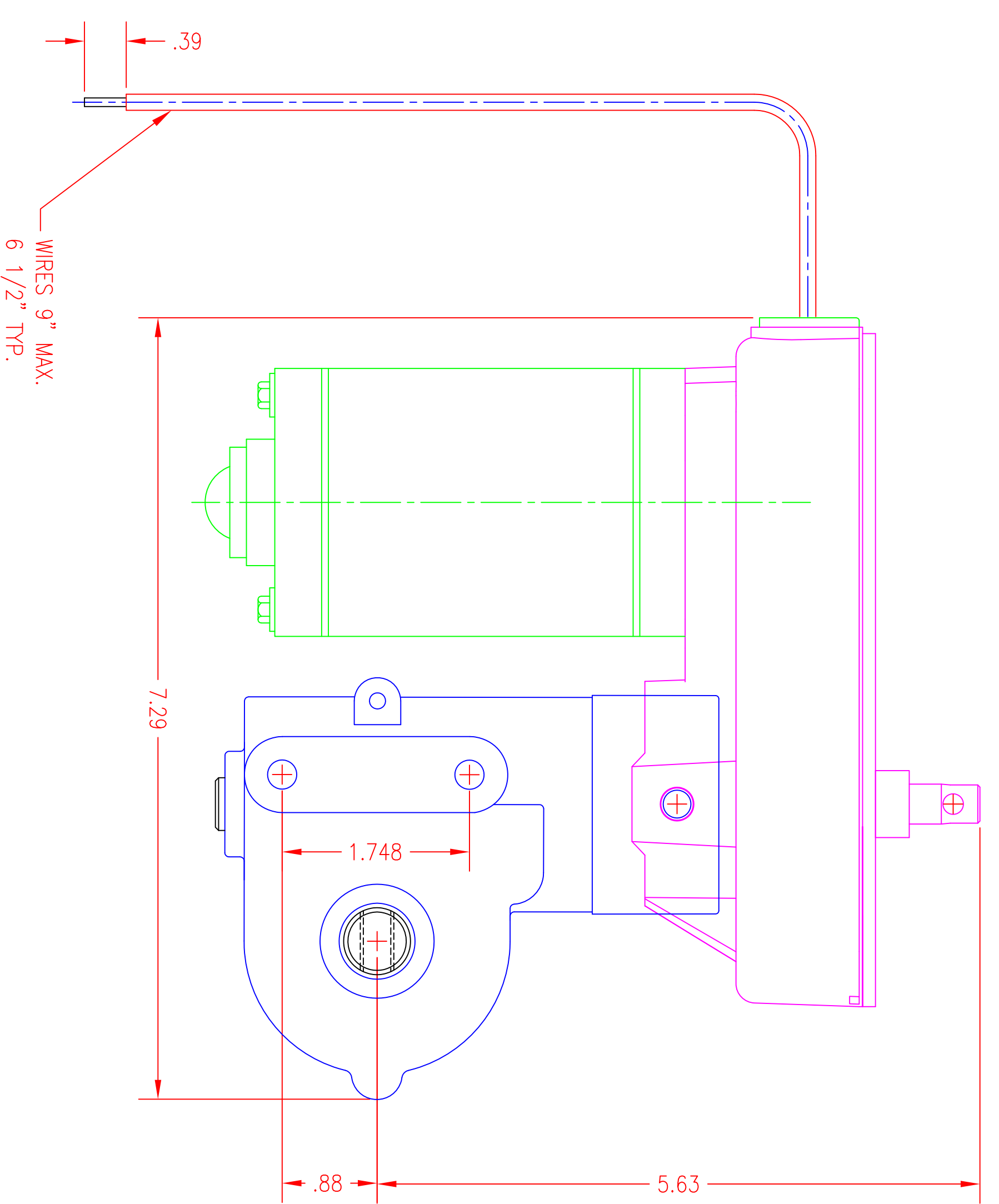
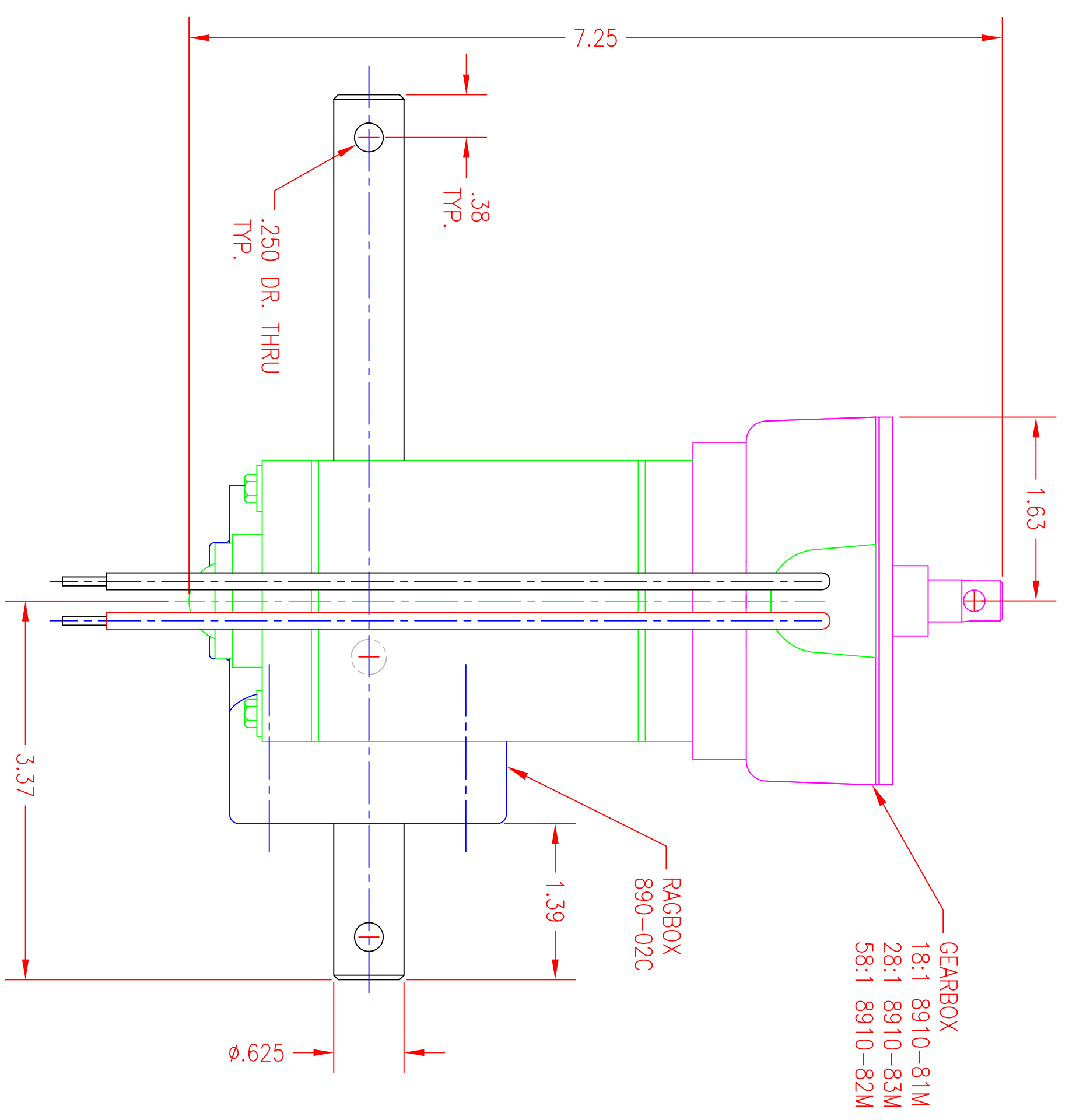

DUAL RIGHT ANGLE DRIVE UNIT

MA-892C-RA B 18:1
 360:1 RADU
 RATED LOAD ~ 400 in-lbs
 RPM @ RATED LOAD 9.5

MA-893C-RA B 58:1
 1160:1 RADU
 RATED LOAD ~ 480 in-lbs
 RPM @ RATED LOAD 4.5

MA-897C-RA B 28:1
 560:1 RADU
 RATED LOAD ~ 480 in-lbs
 RPM @ RATED LOAD 6.5

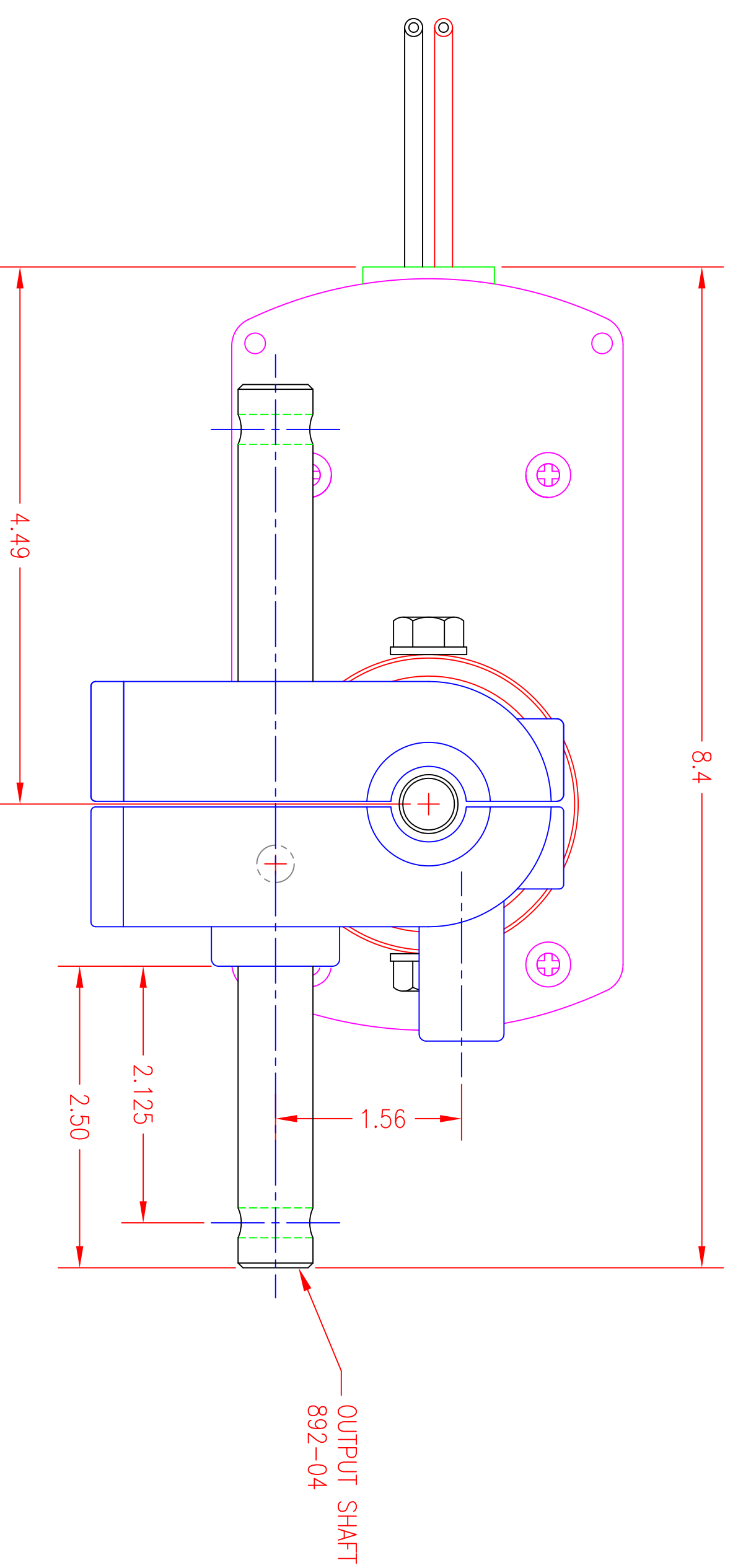
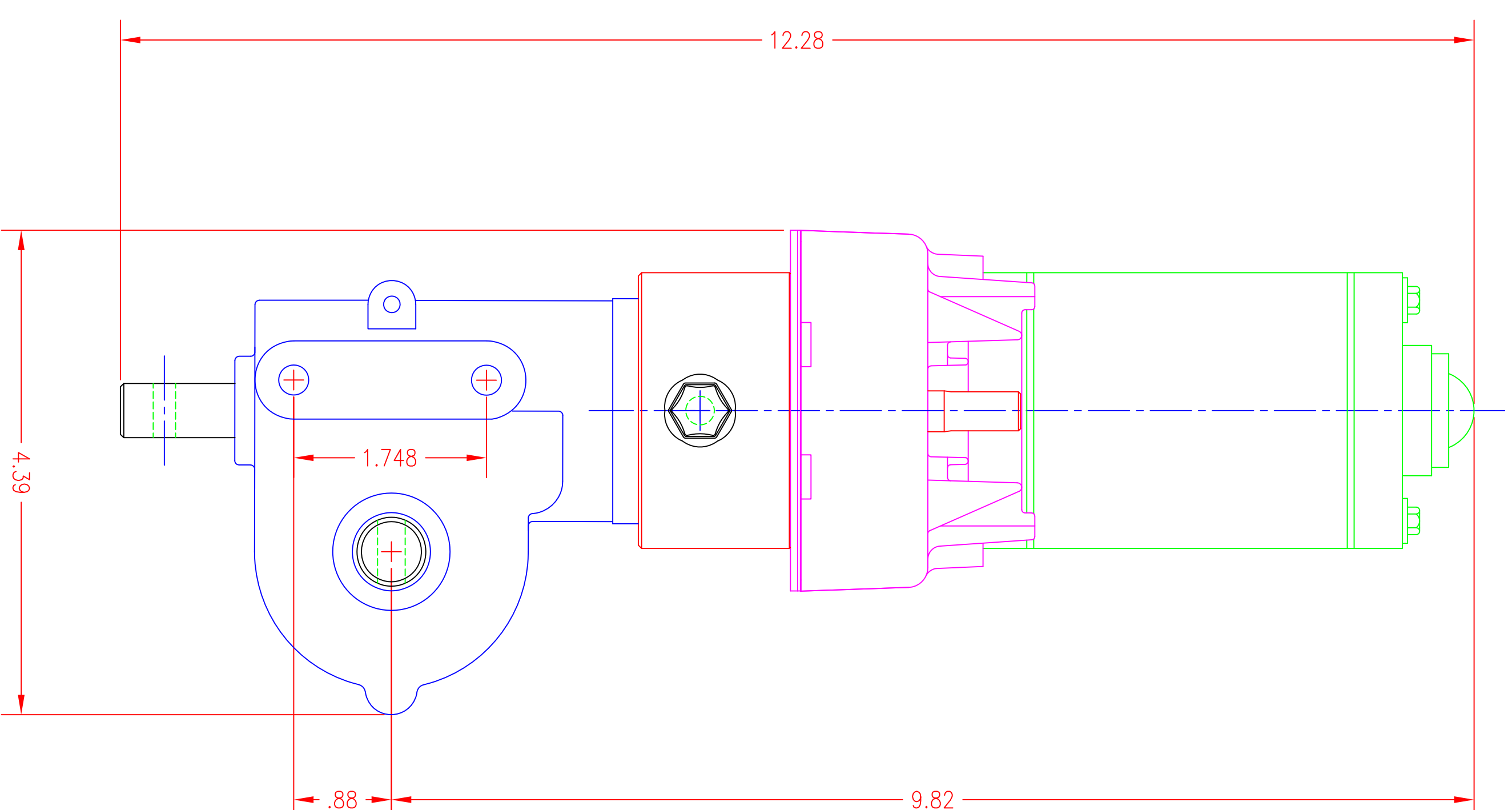
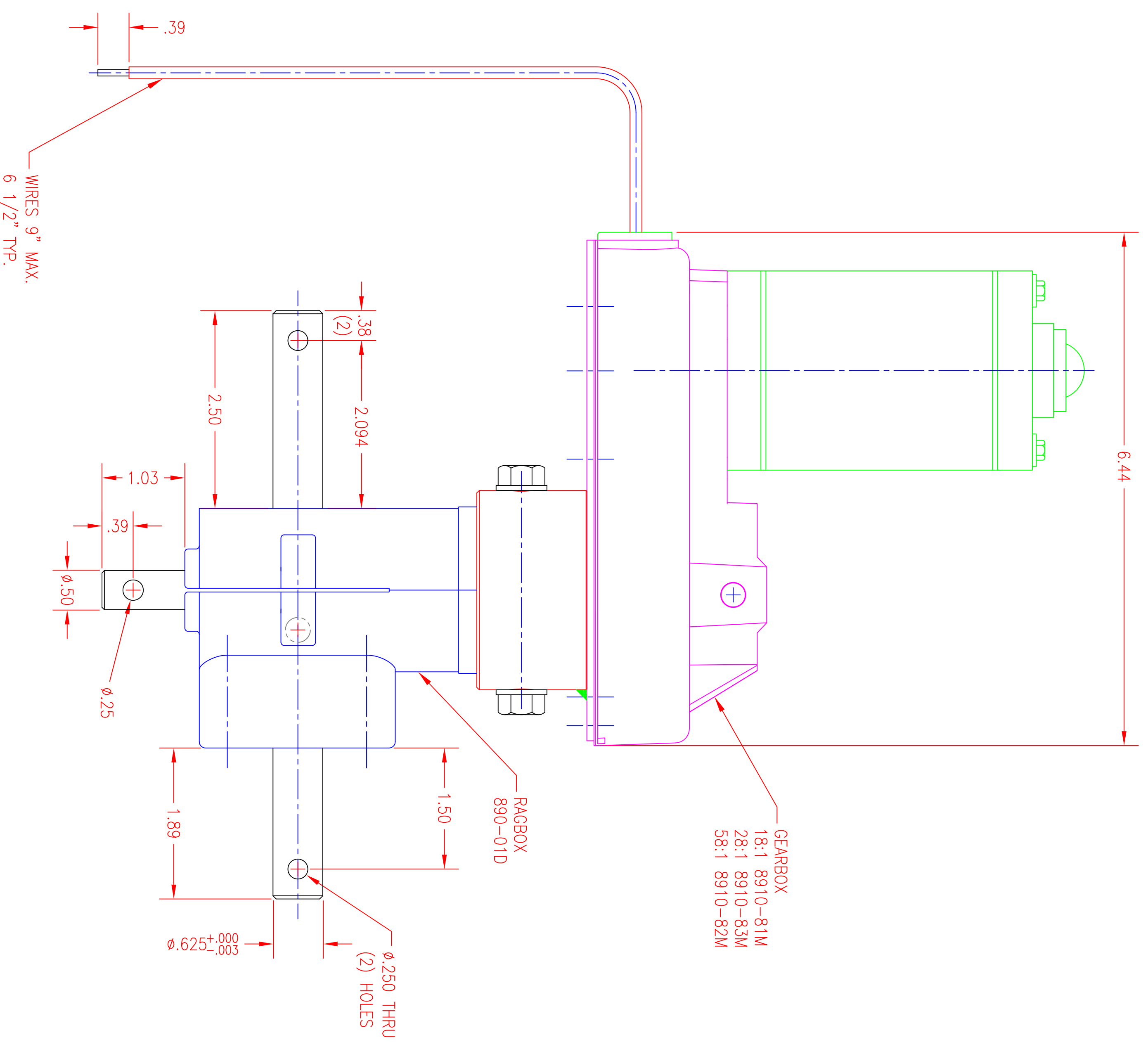

MA-890D-RA LO-PROFILE 18:1
 360:1 RADU
 RATED LOAD ~ 400 in-lbs
 RPM @ RATED LOAD 9.5

MA-891D-RA LO PROFILE 58:1
 1160:1 RADU
 RATED LOAD ~ 480 in-lbs
 RPM @ RATED LOAD 4.5

MA-896D-RA LO PROFILE 28:1
 560:1 RADU
 RATED LOAD ~ 480 in-lbs
 RPM @ RATED LOAD 6.5
 WT ~ 7.8 lbs.